

shipping

Designed
for Success





Gjerdrums vei 19, NO-0484 Oslo, Norway
Tel: +47 21 50 80 70
Fax: +47 21 47 49 01
E-mail: index@index.no
Website: www.index.no
in cooperation with Innovation Norway, the
Confederation of Norwegian Enterprise, the
Norwegian Ministry of Foreign Affairs, the
Research Council of Norway and the Norwegian
Ministry of Trade and Industry.

Managing Director
Norvald M. Heidel

Production Manager
Frode Gulestøl

Editor-in-Chief
Scott LaHart

Editorial Assistant
Robert Moses

Contributing Journalists
Nancy Bazilchuk, Dean Clark, Kristian Kahrs

Coordinator
Lene Risa

Sales Manager
Linda Pettersen

Profile Reservation
Esten Aleksander Edna, Kaja Myhra,
Cathrine Nilsen, Zulaim Zakariyya

Layout
Pia Wagner

Design
Blanke Ark

Printing
Merkur-Trykk AS

The **NORWAY EXPORTS** series provides timely, in-depth information on a selection of Norwegian companies, products and services in over 15 industrial sectors.

NORWAY EXPORTS is distributed free of charge through the Innovation Norway offices and Norwegian foreign service missions (see inside back cover), selected trade publications and at major conferences and trade fairs around the world.

For participation in or more information about **NORWAY EXPORTS**, please contact Index Publishing AS, tel: +47 21 50 80 70 or send an enquiry to index@index.no

The graphic design of this publication, including the font "Aeroportal", is used with the permission of the Norwegian Ministry of Foreign Affairs. It is not to be used without the Ministry's prior consent.

Copyright © 2006 Index Publishing AS

NORWAY EXPORTS is printed on chlorine-free paper.

Cover photo:
© Ulstein Group

facts:

Norway in Brief

Size: 385,155 sq. km
(including the islands of Svalbard and Jan Mayen)

Population 4.64 million

Main Cities	Population (incl. suburbs)
Oslo	801,158
Bergen	242,158
Stavanger/Sandnes	174,104
Trondheim	158,613

GDP 2005 NOK 1.91 trillion

Exchange Rate:

NOK/USD 6.74 (October 2006)
NOK/EUR 8.45 (October 2006)

Exports and Imports 2004

	NOK bill.	USD bill.	Amount of GDP
Total Exports	737	109.4	43.7%
Total Imports	499	74.1	29.6%

Main Export Commodities

Oil & gas, metals, machinery, chemical products, fish & fish products, pulp & paper and ferro alloys

Main Import Commodities

Transport equipment, machinery, chemicals, textiles and metal products



Distribution

Norway Exports – Shipping is distributed through the following channels:

- Innovation Norway's offices and Norwegian embassies and consulates abroad
- The Norwegian Ministry of Foreign Affairs' offices abroad
- The Norwegian Ministry of Trade and Industry
- The Association of Norwegian Maritime Exporters' contacts and network
- The Norwegian Shipowners' Association's contacts and network
- The Association of Norwegian Students Abroad's (ANSA) contacts and network
- Norwegian Chambers of Commerce worldwide
- Official state delegations in Norway and abroad
- The following trade fairs:
 - OTC .07 (Houston, USA) April 30–May 3, 2007
 - Nor-Shipping (Oslo, Norway) June 12–15, 2007
 - NEVA 2007 (St. Petersburg, Russia) September 24–27, 2007

Recipients of Norway Exports – Shipping will include:

- Relevant industry contacts in both the public and private sectors in Norway and abroad
- Relevant departments, politicians, and county and township offices in Norway
- Norwegian maritime companies
- Shipyards, shipping companies, consultants, and engineers in Norway and abroad
- Attendees of international events, meetings and trade shows where Innovation Norway or Norwegian embassies are represented

table of contents

- 2: Alphabetical Listing of Companies
- 3: Foreword by the Norwegian Minister of Trade and Industry
- 4–7: Index by Company & Industry
- 10–29: Norwegian Shipping Articles

10: Norwegian Shipping Overview
Mastery of the Seas

12: Norwegian Ship's Gear, Shipping ICT Applications & Arctic Competence
Arctic & Offshore Competence Gives Competitive Edge

16: Norwegian Shipowners, Shipbuilding & Ship Design
Designed for Success

20: Norwegian Shipping R&D
Marine Technology Frontrunners

24: Norwegian Maritime Cluster
Compete When They Have To, Cooperate When They Can

28: Maritime Environmental Technology
Norwegian Shipping Confronts Pollution

31–83: Company Profiles

84–87: Service Providers

SPECIAL THANKS TO:

Dag Terje Andersen (The Norwegian Minister of Trade & Industry), Jon Berg (Norwegian Shipowners' Association), Halvard Olafsen (Norwegian Maritime Exporters), Julie Rønning (Norwegian Ministry of Trade & Industry)



An interview with historian Even Lange, who is directing a multi-million dollar research project on the history of Norwegian shipping. Thought it's tempting to look to Viking times to explain Norway's maritime ascendancy, the cause can be found in more recent and complex developments...



Creative thinking in maritime design, building and ownership techniques has helped Norway gain particularly strong positions in the areas of oil tankers, chemical tankers, and LNG and offshore ships.



A significant competitive edge for Norwegian shipping is the unique synergies emerging from a well-developed cooperation between all of the major players in the Norwegian maritime cluster.

AC Marine AS	31	Jotron AS	50	Rapp Bomek AS	66
Altech AS	32	Kongsberg Maritime AS	51	Rapp Hydema AS	67
Barwil Unitor Ships Service	33	L-3 Communications Valmarine AS	52	Regatta AS	68
Beha-Hedo Industrier AS	34	Lilaas AS	53	Rolls-Royce Marine	69
Bjørge Steinco Moland	35	Marine Cybernetics AS	54	Scandinavian Electrical Systems	70
Brude Safety AS	36	MARINTEK	55	Scanship Environmental AS	71
Brunvoll AS	37	Masto Wire Service AS	56	Servogear AS	72
Det Norske Veritas (DNV)	38	Miros AS	57	SKIPPER Electronics AS	73
Dualog AS	39	Multi Maritime AS	58	AS Sørlandet Aluminiumsprodukter	74
Eksportfinans ASA	40	National Oilwell Norway AS	59	Star Information Systems AS	75
ENWA AS	41	Navico Norway AS	60	Steinsvik AS	76
Fjerby AS	42	NOR Instruments AS	61	Stromme ASA	77
Frank Mohn AS	43	Norac AS	62	Sylinderteknikk AS	78
Hamworthy	44	Norsk Stål AS	63	Tamrotor Marine Compressors AS	79
Helseth AS	46	Odfjell ASA	64	Telenor Satellite Services AS	80
HERNIS Scan Systems AS	47	Pan Nordic Logistics	85	Tranberg AS	81
J. Martens AS	48	Pareto Securities ASA	86	Umoe Schat-Harding AS	82
Jetpak Norge AS	84	PG Marine Group –		Vestdavit AS	83
Jets Vacuum AS	49	Ing Per Gjerdrum AS	65	Wikborg Rein	87

truly a maritime nation



Norway is the fifth-largest shipping nation in the world. Our shipyards have built a considerable part of the international fleet, our maritime sector employs approximately 90,000 people, and Norwegian companies deliver 7 percent of the world's ship's gear. Norway is truly a maritime nation.

Our position as a world-leading maritime nation is largely due to geography and culture. Located in the periphery of Europe, with long fjords surrounded by inaccessible mountains, the sea has become not only an important means for transportation of goods and people – it is a way of life. From the Viking ships to today's sophisticated hulls, advanced machinery and complex technological equipment, Norway has been renowned for its high-quality ships and ship's gear.

Today, Norway's modern maritime industry stands out as a complete cluster, constituted of shipowners, shipbuilders, ship's gear manufacturers and a range of maritime service providers. Together, they have managed to adjust to ever-changing global markets. As this publication

illustrates, they are providing innovative technology and state-of-the-art products for customers worldwide.

Continuous efforts are needed to maintain this position. The Norwegian Government has therefore defined the maritime sector as one of five high-priority areas. We are also committed to working along with the maritime industry to promote maritime research and innovation. One important initiative is MARUT, a joint project that has proven successful in triggering increased research activity and innovative projects.

This year, we introduced a programme called the Norwegian Centres of Expertise to promote cluster-based innovation and internationalization. One of the six centres already established is based on the maritime industry situated around Ålesund on the west coast of Norway. Several of the other centres also relate to the maritime sector.

Next year, the Government will be presenting a national maritime strategy, identifying the challenges we have to face, as well as the ambitions we will pursue in order to remain a leading maritime nation.

To Norway, taking care of the global maritime environment is both a challenge and an ambition. Today, shipping carries

more than 90 percent of world trade. This is largely due to the fact that shipping is a cost-effective, reliable and safe mode of transport. It is also relatively clean. However, there are still several unresolved issues with regard to the environmental impact of maritime transport. These challenges need to be taken very seriously, and we are deeply committed to cooperating internationally as well as on the national level in order to spur a positive development in this field.

I believe one way of dealing with environmental issues is to increase our efforts on innovation in this area. Norway has become a frontrunner in this field, as the world's first LNG-driven vessels have been built in Norway. Five new LNG-driven ferries, all developed and built in Norway, will operate in Norwegian fjords from 2007.

This publication provides insight into the unique Norwegian maritime cluster, and information on what our maritime industry can offer its international partners. I find it impressive, and I believe you will find it worthwhile to pursue your business ambitions along with some of the world's most professional and competent maritime companies that are presented on the following pages.

products & equipment

ALARM, MONITORING & CONTROL SYSTEMS**Automation Systems**

Bjorge Steincø Moland	.35
Kongsberg Maritime AS	.51
L-3 Communications Valmarine AS	.52
Rolls-Royce Marine	.69
Scandinavian Electrical Systems	.70

Ballast Control Systems

Altech AS	.32
Bjorge Steincø Moland	.35
Hamworthy	.44
L-3 Communications Valmarine AS	.52

Bilge Control Systems

L-3 Communications Valmarine AS	.52
---------------------------------	-----

Cargo Control Systems

Bjorge Steincø Moland	.35
Hamworthy	.44
Kongsberg Maritime AS	.51
L-3 Communications Valmarine AS	.52

Communications Systems for Remote Monitoring

Bjorge Steincø Moland	.35
Dualog AS	.39
HERNIS Scan Systems AS	.47
National Oilwell Norway AS	.59

Condition Monitoring Systems

Bjorge Steincø Moland	.35
Kongsberg Maritime AS	.51
NOR Instruments AS	.61
Star Information Systems AS	.75

Emergency Shutdown Systems

L-3 Communications Valmarine AS	.52
---------------------------------	-----

Fire Detection & Alarm Systems

Barwil Unitor Ships Service	.33
Bjorge Steincø Moland	.35

Fire Water Pump Control Systems

Hamworthy	.44
-----------	-----

Level Gauging & Tank Control Systems

Altech AS	.32
Bjorge Steincø Moland	.35
Kongsberg Maritime AS	.51

Manoeuvring & Propulsion Remote Control Systems

Brunvoll AS	.37
Kongsberg Maritime AS	.51
Lilaas AS	.53

Meteorological & Oceanographic Systems

Miros AS	.57
----------	-----

Power Management Systems

L-3 Communications Valmarine AS	.52
---------------------------------	-----

Propulsion Control Systems

Kongsberg Maritime AS	.51
L-3 Communications Valmarine AS	.52
Lilaas AS	.53

Remote Sounding Systems

Altech AS	.32
Bjorge Steincø Moland	.35

Safety Management Systems

L-3 Communications Valmarine AS	.52
---------------------------------	-----

Sensors & Transmitters

Bjorge Steincø Moland	.35
Kongsberg Maritime AS	.51

Valve Remote Control Systems

Altech AS	.32
Bjorge Steincø Moland	.35

Vessel Monitoring Systems

Miros AS	.57
Star Information Systems AS	.75
Steinsvik AS	.76

CARGO EQUIPMENT**Cargo Control Equipment**

Altech AS	.32
Bjorge Steincø Moland	.35
Hamworthy	.44
Kongsberg Maritime AS	.51
L-3 Communications Valmarine AS	.52

Cargo Handling Equipment & Lifts

Hamworthy	.44
Rapp Hydema AS	.67

Cargo Pumps

Frank Mohn AS	.43
Hamworthy	.44
PG Marine Group - Ing Per Gjerdrum AS	.65

Cargo Valves

Altech AS	.32
-----------	-----

Deck Cranes & Accessories

National Oilwell Norway AS	.59
Stromme ASA	.77

Fenders

Stromme ASA	.77
-------------	-----

Hatch Cover Seals

Barwil Unitor Ships Service	.33
-----------------------------	-----

Inert Gas & Nitrogen Systems

Hamworthy	.44
-----------	-----

Liquid Cargo Handling Systems

Altech AS	.32
Frank Mohn AS	.43
Hamworthy	.44
Kongsberg Maritime AS	.51

MACHINERY, MAIN COMPONENTS**CP Propeller Systems**

Masto Wire Service AS	.56
Rolls-Royce Marine	.69
Servogear AS	.72

Diesel Engines

ENWA AS	.41
Rolls-Royce Marine	.69

Engine Room Pumps

Hamworthy	.44
PG Marine Group - Ing Per Gjerdrum AS	.65

Mechanical Power Transmission Systems & Gears

National Oilwell Norway AS	.59
Servogear AS	.72

Power Packs

PG Marine Group - Ing Per Gjerdrum AS	.65
---------------------------------------	-----

Propulsion Systems

Helseth AS	.46
Kongsberg Maritime AS	.51
Masto Wire Service AS	.56
NOR Instruments AS	.61
Scandinavian Electrical Systems	.70
Servogear AS	.72

Shaft, Auxiliary, Emergency Generators & UPS

Rolls-Royce Marine	.69
Scandinavian Electrical Systems	.70

Valves

Altech AS	.32
-----------	-----

MAINTENANCE EQUIPMENT & SUPPLIES**Air Compressors**

Barwil Unitor Ships Service	.33
Stromme ASA	.77
Tamrotor Marine Compressors AS	.79

Air Dryers

Stromme ASA	.77
Tamrotor Marine Compressors AS	.79

Anti-Skid Coatings

Fjerby AS	.42
-----------	-----

Cathodic Protection

ENWA AS	.41
---------	-----

Coatings & Corrosion Treatment

Barwil Unitor Ships Service	.33
-----------------------------	-----

Compressed Air Dryers & Filters

Barwil Unitor Ships Service	.33
ENWA AS	.41
Stromme ASA	.77
Tamrotor Marine Compressors AS	.79

Marine Chemicals

Barwil Unitor Ships Service	.33
Scanship Environmental AS	.71
Stromme ASA	.77

Microbes for Grease & Odour Elimination

Barwil Unitor Ships Service	.33
-----------------------------	-----

Paint Spraying Equipment

Barwil Unitor Ships Service	.33
-----------------------------	-----

Surface Preparation Equipment

Barwil Unitor Ships Service	.33
-----------------------------	-----

Vacuum Cleaning Systems

Barwil Unitor Ships Service	.33
-----------------------------	-----

Welding Equipment

Barwil Unitor Ships Service	.33
-----------------------------	-----

Wire Rope Lubricators

Barwil Unitor Ships Service	.33
Masto Wire Service AS	.56

SHIP'S EQUIPMENT**Accommodation Modules, Ceilings, Wall Panels & Doors**

Norac AS	.62
----------	-----

Anchor Handling, Mooring Systems & Deck Machinery

National Oilwell Norway AS	.59
Rapp Hydema AS	.67
Rolls-Royce Marine	.69

Antennas

Navico Norway AS	.60
------------------	-----

Ballast Water Treatment Systems

PG Marine Group - Ing Per Gjerdrum AS	.65
Scanship Environmental AS	.71

Bilge Water Separators

Hamworthy	.44
-----------	-----

Cables & Ropes

Brude Safety AS	.36
-----------------	-----

Catwalks, Gangways, Ladders, Landings, Ramps & Staircases

Brude Safety AS	.36
-----------------	-----

Closed-Circuit Television Systems

HERNIS Scan Systems AS	.47
------------------------	-----

Davits & Launching Equipment

Brude Safety AS	.36
Stromme ASA	.77
Umoe Schat-Harding AS	.82
Vestdavit AS	.83

Doors

Norac AS	.62
Rapp Bomek AS	.66

Electric Heaters

Tranberg AS	.81
-------------	-----

Electric Motors

PG Marine Group - Ing Per Gjerdrum AS	.65
Scandinavian Electrical Systems	.70

Emergency Towing Systems

Rapp Bomek AS	.66
---------------	-----

Fire Detection & Extinguishing Equipment

Barwil Unitor Ships Service	.33
Bjorge Steincø Moland	.35
Brude Safety AS	.36

Fire Doors

Norac AS	.62
Rapp Bomek AS	.66

Fire Fighting Units

Stromme ASA	.77
-------------	-----

Furniture

Beha-Hedo Industrier AS	.34
Norac AS	.62
AS Sorlandets Aluminiumsprodukter	.74
Steinsvik AS	.76

Galley Equipment

Beha-Hedo Industrier AS	.34
-------------------------	-----

Generators, Switchboards & Transformers

Scandinavian Electrical Systems	.70
---------------------------------	-----

Heating, Ventilation & Air Conditioning (HVAC) Systems

AC Marine AS	.31
--------------	-----

Hospital Equipment

Brude Safety AS	.36
-----------------	-----

Hydraulic Components & Control Units

Altech AS	.32
Navico Norway AS	.60
NOR Instruments AS	.61
Sylinderteknikk AS	.78

Hydrophore Units & Pressure Vessels

PG Marine Group - Ing Per Gjerdrum AS	.65
---------------------------------------	-----

Industrial Monitors

HERNIS Scan Systems AS	.47
------------------------	-----

Lighting Systems

Tranberg AS	.81
-------------	-----

Line-Throwing Devices

Brude Safety AS	.36
Stromme ASA	.77

Marine Environment Protection Equipment

Brude Safety AS	.36
Frank Mohn AS	.43

Mooring Tools

Brude Safety AS	.36
National Oilwell Norway AS	.59
Rapp Bomek AS	.66

Navigation, Signal & Marker Lights

Tranberg AS	.81
-------------	-----

Safety & Life-Saving Equipment

Barwil Unitor Ships Service	.33
Brude Safety AS	.36
Jotron AS	.50
Navico Norway AS	.60
Regatta AS	.68
Stromme ASA	.77
Vestdavit AS	.83

Sanitation Equipment & Prefabricated Wet Units

Jets Vacuum AS	.49
Norac AS	.62

Steel Shipbuilding Profiles

Norsk Stål AS	.63
---------------	-----

Steering Gear

Rolls-Royce Marine	.69
--------------------	-----

Survival Clothing & Suits

Barwil Unitor Ships Service	.33
Brude Safety AS	.36
Regatta AS	.68
Stromme ASA	.77

Survival Craft, Rescue Boats & Free-Fall Lifeboats

Barwil Unitor Ships Service	.33
Brude Safety AS	.36
Stromme ASA	.77
Umoe Schat-Harding AS	.82

Trawling Equipment

Rapp Hydema AS	.67
Rolls-Royce Marine	.69

Tunnel & Retractable Thrusters

Helsest AS	.46
Rolls-Royce Marine	.69

Ventilation, Air Conditioning & Heating Systems

AC Marine AS	.31
ENWA AS	.41
Stromme ASA	.77

Venting Equipment

ENWA AS	.41
---------	-----

Waste Treatment Equipment

ENWA AS	.41
Scanship Environmental AS	.71

Water Makers

ENWA AS	.41
---------	-----

Water Treatment Equipment

ENWA AS	.41
Hamworthy	.44
Scanship Environmental AS	.71
Stromme ASA	.77

Watertight Doors

Rapp Bomek AS	.66
---------------	-----

Watertight Doors (Hinged & Sliding)

Norac AS	.62
Rapp Bomek AS	.66

Windows, Fire-Rated Windows & Side Scuttles

Norac AS	.62
Rapp Bomek AS	.66

Workshop Equipment

Brude Safety AS	.36
Stromme ASA	.77

information & communications technology**COMMUNICATIONS SYSTEMS****Land-Based Communications Systems**

Jotron AS	.50
Telenor Satellite Services AS	.80

Satellite Communications Systems

Dualog AS	.39
Jotron AS	.50
Telenor Satellite Services AS	.80

Shipboard Communications Systems

Dualog AS	.39
Jotron AS	.50
Telenor Satellite Services AS	.80

COMPUTER SYSTEMS**Loading Computers**

Bjorge Steingo Moland	.35
-----------------------	-----

DATABASES**Fleet & Ship Management Database**

MARINTEK	.55
Star Information Systems AS	.75

NAVIGATION & POSITIONING EQUIPMENT & SYSTEMS**Fish-Finding Equipment**

Kongsberg Maritime AS	.51
SKIPPER Electronics AS	.73

Global Positioning Systems (GPS)

SKIPPER Electronics AS	.73
------------------------	-----

Integrated Bridge Systems

Kongsberg Maritime AS	.51
L-3 Communications Valmarine AS	.52
SKIPPER Electronics AS	.73

Search & Navigation Equipment

Jotron AS	.50
L-3 Communications Valmarine AS	.52
SKIPPER Electronics AS	.73

Speed Logs

SKIPPER Electronics AS	.73
------------------------	-----

Voyage Recorders

Kongsberg Maritime AS	.51
L-3 Communications Valmarine AS	.52
Miros AS	.57

Wave Monitoring Systems

Miros AS	.57
----------	-----

SOFTWARE**Administrative, Maintenance, Operation & Procurement Systems**

MARINTEK	.55
Star Information Systems AS	.75

Design Software

MARINTEK	.55
----------	-----

Training Software

Kongsberg Maritime AS	.51
MARINTEK	.55
Star Information Systems AS	.75

consultancy & other services**CLASSIFICATION**

Det Norske Veritas (DNV)	.38
--------------------------	-----

CONSULTANCY**Cartography**

Marine Cybernetics AS	.54
-----------------------	-----

Certification, Testing & Laboratory Services

Det Norske Veritas (DNV)	.38
MARINTEK	.55

Communications & IT Services

Dualog AS	.39
HERNIS Scan Systems AS	.47
MARINTEK	.55
Star Information Systems AS	.75
Telenor Satellite Services AS	.80

Corrosion Monitoring

Det Norske Veritas (DNV)	.38
--------------------------	-----

Design, Engineering & Package Deliveries

MARINTEK	.55
Multi Maritime AS	.58
Rolls-Royce Marine	.69

Inspection

Det Norske Veritas (DNV)	.38
--------------------------	-----

Marine Environment Protection Consultancy

Det Norske Veritas (DNV)	.38
MARINTEK	.55
Miros AS	.57

Naval Architecture & Marine Engineering

MARINTEK	.55
Multi Maritime AS	.58
Rolls-Royce Marine	.69
Star Information Systems AS	.75

Research & Development

Det Norske Veritas (DNV)	.38
MARINTEK	.55
Multi Maritime AS	.58
Star Information Systems AS	.75

FINANCING

Eksportfinans ASA	.40
Pareto Securities ASA	.86
Wikborg Rein	.87

SHIPBUILDING**Construction, Repair & Conversion**

Wikborg Rein	.87
--------------	-----

Maintenance Contracts

Wikborg Rein	.87
--------------	-----

TRAINING**Training Programmes**

MARINTEK	.55
Scandinavian Electrical Systems	.70
Star Information Systems AS	.75

Training Simulators

Kongsberg Maritime AS	.51
MARINTEK	.55

TRANSPORT & LOGISTICS

J. Martens AS	.48
MARINTEK	.55
Odfjell ASA	.64
Wikborg Rein	.87



– We give local ideas global opportunities

Innovation Norway offers products and services to increase innovation in industry throughout Norway, to help develop the regions and promote Norwegian industry and internationalization, and to promote Norway as a tourist destination.

With offices in more than 30 countries worldwide and in all Norwegian counties, Innovation Norway is easy to reach. Our staff has knowledge of local and international factors that will help turn our customers' ideas into business successes.

Products Tailor-Made to Customers' Requirements

Innovation Norway assists the entirety of Norwegian industry, but has particular responsibility for aiding entrepreneurs and assisting small and medium-sized companies with an ambition and potential for growth.

We offer:

- Funding provided as loans, guarantees and equity capital programmes
- Advisory and expertise development measures

- National and international network-building and technology transfer
- Marketing of Norwegian industry and Norway as a tourist destination

With these measures as a point of departure, Innovation Norway customizes its products and services according to the needs of each individual client. Through our offices in Norway and abroad, our clients also gain access to services from other public agencies – such as the Research Council of Norway, the Norwegian Design Council and the Industrial Development Corporation of Norway (SIVA).

Dynamic and Result-Oriented

Innovation Norway supports the profitable development of industry in both individual companies and in society at large:

- Innovation Norway contributes to the creation and securing of 9,000 jobs annually

- Customer surveys show that 90 percent of Innovation Norway's funds have been allocated to projects viewed as important to companies' survival and profit growth

Innovation Norway

PO Box 448 Sentrum
NO-0104 Oslo, Norway
Tel: +47 22 00 25 00
Fax: +47 22 00 25 01
E-mail: post@invanor.no
Website: www.innovationnorway.no

Innovation Norway took over the tasks of the Norwegian Trade Council, the Norwegian Industrial and Regional Development Fund, the Govt. Consultative Office for Inventors and the Norwegian Tourist Board on January 1, 2004.

the association of norwegian maritime exporters (nme)

For more than three decades, the Association of Norwegian Maritime Exporters (NME) has served as a vital link between Norwegian maritime companies both at home and abroad. And, operating in an industry characterized by fierce competition and the emergence of dynamic new markets, NME is now busier than ever.

Building Networks at Home & Abroad

While engaged in a broad range of activities, NME is driven by one core ambition: establishing networks. NME represents many of Norway's most ambitious and innovative companies, from established multinationals to specialist niche players serving a wide variety of different markets. NME has always focused on bringing together companies in the Norwegian shipping cluster, but in an increasingly global industry, NME has stepped up its efforts to engage with international markets.

A Gateway to Emerging Markets

Over the past five years, NME has been quick to recognize the vast potential in emerging markets, organizing promotional tours to Brazil, Vietnam and India, among others. NME has also continued to build strong relationships with international exhibitions, such as SMM, Marintec China, Seatrade, Kormarine, and many more. With years of experience organizing national pavilions or working to secure favourable exhibition space for members, NME has become a vital link between international exhibitions and domestic maritime markets.

In Norway, NME's influence remains strong. In addition to its flagship event (the annual ERFA Conference), NME works closely with the Norwegian Ministry of Trade & Industry, the Norwegian Shipowners' Association, Maritimt Forum, and Innovation Norway among other maritime organizations to coordinate events and enable members to strengthen or establish relationships with new or potential Norwegian customers.

The Power of Independence

Since 1998, NME has been a wholly independent, member-supported organization. This allows NME members to set their own agenda, and respond rapidly to changing market forces. Indeed, many members have used the organization to seek out alliances with other members for joint ventures or to partner in developing new technologies. NME members are also active in suggesting various conferences, seminars and workshops on subjects ranging from managing regulatory challenges to optimizing marketing efforts at both domestic and international exhibitions.

NME has worked steadily to improve its organizational and administrative capacity. In addition to a four-member board of

directors, NME has a five-person team responsible for marketing, and plans are currently underway to pinpoint members with specific expertise in different market segments to be sourced by other members seeking specific expertise. Plans to launch a new communications strategy and redesign NME's website are underway. NME will also work more closely with similar organizations in Europe and seek to strengthen member ties to the maritime elements of the offshore industry.

Enduring Success

Norway's maritime cluster has a strong tradition of technical innovation, cooperation between different players and keeping an international perspective. And while no organization can take all the credit, it is perhaps no surprise that NME continues to be regarded as an important link between member companies in Norway and the international maritime industry.



The Association of Norwegian Maritime Exporters

PO Box 1927 Vika
NO-0125 Oslo, Norway
Tel: +47 22 01 06 60
Fax: +47 22 01 22 02
E-mail: postmaster@maritimenorway.no
Website: www.maritimenorway.no



The Norwegian pavilion at the VietShip international exhibition in Hanoi, February 2006.

mastery of the seas



By Nancy Bazilchuk

Norway has always looked to the sea for its livelihood – and successfully so. But what may be surprising is Norway’s dominance in its mastery of the seas. Although it has just a fraction of the world’s population, Norway has established one of the 10 largest merchant fleets in the world, with nearly 1,700 ships representing 39 million deadweight tonnes. The country’s recognition of the importance of shipping has fuelled the nation’s leadership in shipbuilding, fisheries, and offshore petroleum production, as well as a keen desire to foster innovation and uphold high standards for services, training and environmental protection.

“Norway is a strong maritime nation, with a long and proud maritime history,” Norwegian Prime Minister Jens Stoltenberg told the European Maritime Industries Forum when it came to Oslo in October 2006, the first time the meeting had been held in a non-EU member country. “Sea travel connects us – with Europe, the world and each other.”

University of Oslo historian Even Lange says it’s tempting to look to Viking times to explain Norway’s ascendancy as a maritime nation – but the cause can be found in more recent and complex developments. Lange is directing a research project on the history of Norwegian shipping, with the first volume of the series due in 2009, the 100th anniversary of the Norwegian Shipowners’ Association.

“The 19th century is when Norwegian shipping established its important position,” Lange said. “From the 1830s–1890s,

Norway made the jump from an insignificant maritime nation to a leading shipping country.”

Lange says Norwegians were able to assume their leadership in part because of skills that are still important today:

- Norwegians put the training they received to good use
- Norwegian skippers and crews were widely recognized as highly efficient
- Norwegian companies adopted new technologies at the right time
- Norwegians benefited from specialization in shipping

At the same time, the rough seas of the North Atlantic and the icy perils of Arctic waters have driven Norwegians to be innovative in developing ways to cope with tough maritime conditions.

Four Hundred Years of Training

Understanding Norway’s development as a maritime powerhouse requires an overview of the country’s last 600 years of history, Lange says. From the Kalmar Union in 1397 right through to the end of the Napoleonic Wars in 1814, Norway was in a union with Denmark. The Danish crown governed a small empire, with outposts in the West Indies and India, which allowed Norwegians to learn the intricacies of long-distance trade. “Norwegians had their training inside the Danish system and its micro-empire,” Lange said.

These days, Norwegians leave nothing to chance when it comes to training the next generation of mariners, and to retaining skilled employees. For example, in 2005, the Norwegian Shipowners’ Association launched an ongoing two-year trainee

programme on behalf of the Norwegian maritime industry and involving 21 different companies. The programme can draw on the Norwegian maritime cluster in its offerings; shipowners, shipyards, maritime equipment companies, oil rig companies, classification societies, law firms, banks and shipbrokers are all active participants.

Once they’re in the workforce, maritime workers can also depend on strong support from Norway. The country was an active contributor to the crafting of an international Maritime Labour Convention, which was adopted in February 2006 and consists of minimum standards for workers and fair competition for employers. “In order to attract and retain skilled employees, we need to ensure good working conditions,” said Dag Terje Andersen, Norway’s Minister of Trade and Industry, at the 2006 Maritime Industry Forum in Oslo. “Norway welcomes this convention.”

Efficient & Willing to Work

Until the last quarter of the 19th century, the ship’s captain was key in determining a ship’s cargo. Harbours were meeting places where captains would connect with merchants eager to send their wares abroad. Thus, a captain’s negotiating skills and his track record inevitably made a difference. Norwegians excelled at these

tasks, Lange noted, which helped build the Norwegian fleet. Plus, Norwegian seamen were known for their meticulousness with cargo, and their efficiency in loading and offloading goods.

“Norwegians had the reputation of being quick in and out of harbours, and they took care with their loads,” Lange said. “So they had this reputation and they were in demand.”

As the 1800s progressed, the Norwegian fleet expanded, particularly in moving bulky items like coal and wood. But the world was changing. As the century ended, many maritime nations were shifting to steamships powered by coal. Norway stayed with sail, however, because in moving goods that didn’t need rapid transport, sails were more profitable – at first. By 1890, Norwegian vessels carried nearly 8 percent of the world’s cargo – a high point. But after 1890, steam began to dominate, and Norway’s share of the maritime trade dropped by nearly one-half during from 1890 to 1920.

Adopting New Technologies – And Developing Them

Some think Norwegian shipowners lingered too long with sail, but Lange says they

stayed with the old technology for good economic reasons. The slow transition to steam was followed by a very rapid transition to diesel-powered vessels – driven by a shift to more specialized kinds of shipping, particularly tankers, a move that continues to pay dividends today.

The modern Norwegian fleet is highly specialized. The discovery of North Sea oil in the 1960s spurred the growth of ships designed to handle the rigours of the North Atlantic and the Arctic, and to deliver specialized services, from anchor handlers to supply ships. In fact, Norway has 15 percent of the world’s fleet for offshore services.

Norwegians continue to invest in ships and the sea, as befits the country’s heritage and its economic success. Norwegian shipowners had NOK 64 billion worth of ships on order at the beginning of 2006, representing 4 percent of the world’s total. Since the 1990s, Norway has held one of the leading positions in supply shipping, providing for oil installations across the globe. “It’s a new speciality for Norway,” Lange notes. “And it has been lifting the Norwegian shipping industry out of the crisis of the 1970s to new heights.”

The transition from sails to steam was a decisive one in the history of Norwegian shipping. Steam was fast, and was used to transport people and perishable goods, but Norwegian captains were able to exploit the benefits of sail in moving coal, wood, and other heavy, non-perishable goods.



© Aker Yards

This UT 741 offshore support vessel is an example of the kinds of specialization that now characterizes the Norwegian shipping industry.



© Rolls-Royce



arctic & offshore

competence gives competitive edge

By Kristian Kahrs

In the international maritime industry, the 4.6-million-person nation of Norway is a world leader in such areas as ship's gear and shipping IT applications, to name a few. Furthermore, the country's closeness to the rough and challenging Arctic nature – and the great care taken to educate personnel in the industry to handle such conditions – gives Norway an important competitive edge.

Arctic Bow Loading of Crude Oil

A world leader in the design and supply of all types of deck machinery and mooring systems for marine and offshore applications, Aker Kværner and its Aker Kværner Pusnes division knows that shipping gear demands high quality in Arctic conditions.

There are many environmental concerns operating in the fragile Arctic ecosystem, but Leif Haukom, the president of Aker Kvaerner Pusnes, also understands that technology does not develop in a vacuum. The company has designed and implemented a bow loading system for crude oil operating in Arctic conditions, and Haukom believes it is possible to exploit petroleum resources without too much risk to the environment.

"What is important with our system is that it is it has zero emissions and is designed to operate in temperatures as low as -46°C," he says.

In contrast to the more traditional bow loading systems, this alternative system involves offshore loading in which the 20-inch hose connection point is located well within the deck area of the shuttle tanker. Traditional shuttle tankers have an external connection point (coupler) protruding from the bow of the shuttle tanker during loading. A dedicated mooring system is included as part of the total equipment package for securing the shuttle tanker to the offloading facility.

Together with Rolls-Royce Marine, Aker Kværner Pusnes dominates the market for deck machinery and mooring systems with a combined market share of more than 60 percent. And Aker Kværner is the world's leading producer of offshore loading systems.

"Annually, we supply deck machinery to more than 160 ships worldwide. Strong markets and competitive solutions strengthen our position," he says.

Safety at Sea

Every year, sailors around the world pay the ultimate price because of the unpredictable nature of the rough seas, but Norwegian technology helps to reduce the risks. Taking advantage of advanced remote control systems to reduce the amount of dangerous manual labour on the deck, Rolls-Royce has developed something it considers a small revolution. Previously, seamen would have to go into hazardous areas on an offshore vessel, but the future is safer.

"We have developed a safer deck crane system with special lifting arms to work together with winches and other moving equipment to and from any point on the deck, as well as reach over the side and the stern," explains Arne Tande, vice president of offshore deck machinery for Rolls-Royce.

Proper winch systems are vital for security purposes. "Today the winch systems produced (by Rolls-Royce) have practically

become an industry standard for offshore, merchant, fishing and naval applications," says Tande.

Companies like Brude Safety have also been synonymous with reducing the risk in hazardous waters. It offers complete packages of safety equipment from quality producers. "From the safety plan of the ship or installation we work out comprehensive solutions for the overall rescue and safety equipment onboard," says Brude marketing manager Lauritz Skeide. "Examples could include marine evacuation systems, rescue boats and davits, fire-fighting systems, survival equipment, nautical equipment and other ship equipment," he says.

Dynamic Positioning

Sometimes mooring is not feasible because of deep waters, and then dynamic positioning (DP) is the name of the game in order to keep a ship in a constant position or to keep the position over a moving object in rough seas using the ship's own propellers and thrusters.

With close to a 70 percent market share in the DP market, Kongsberg is a world leader in developing such systems. To keep its position, it has to be on the forefront of innovation and satisfy the industry with advanced technology.

Kongsberg Maritime marketing manager Roy Larsen is especially satisfied with the company's K-Pos Dynamic Positioning Controller, released in 2006. "Our new Dynamic Positioning Controller is smarter, simpler and safer, providing users with more operational reliability and less cost of ownership," he says. "Our technology is being implemented across a wide range of key shipboard systems, providing a real difference in operation."

However, simply supplying DP systems is not enough for Kongsberg. It wants to supply the industry with complete DP, automation and navigation packages in order to solve advanced challenges.

"Our equipment here really runs the gamut. By integrating the various control systems such as automation and process control,

dynamic positioning, navigation and hydro-acoustic products into a single process, we can to a greater extent tailor-make overall solutions," says Larsen.

Supplying a very wide range of ship technology, design and ship's gear, British-owned Rolls-Royce, with its maritime headquarters and competence in Norway's northwestern Møre coast, also finds dynamic positioning of interest. Rolls-Royce Marine is a global leader in the full range of ship's gear, and therefore it is natural for the company to expand its markets.

"It is logical for us to supply DP when we supply so many other equipment areas onboard, and we have detailed knowledge of most of the subsystems included in a DP operation," says Rolls-Royce Marine department manager Gunnar Nyland.

An illustration of Aker Kværner Pusnes' Arctic bow loading system for crude oil loading. The system can load oil in temperatures as low as -46°C.

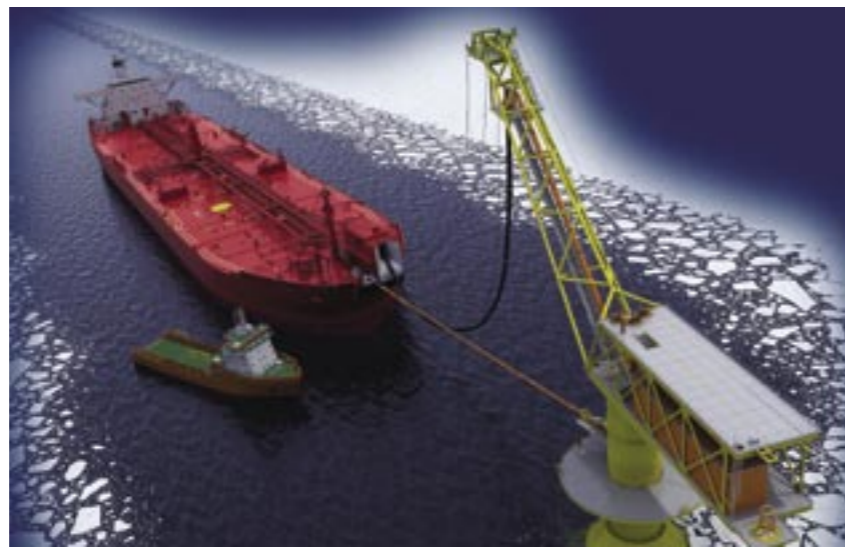

© Aker Kværner Pusnes

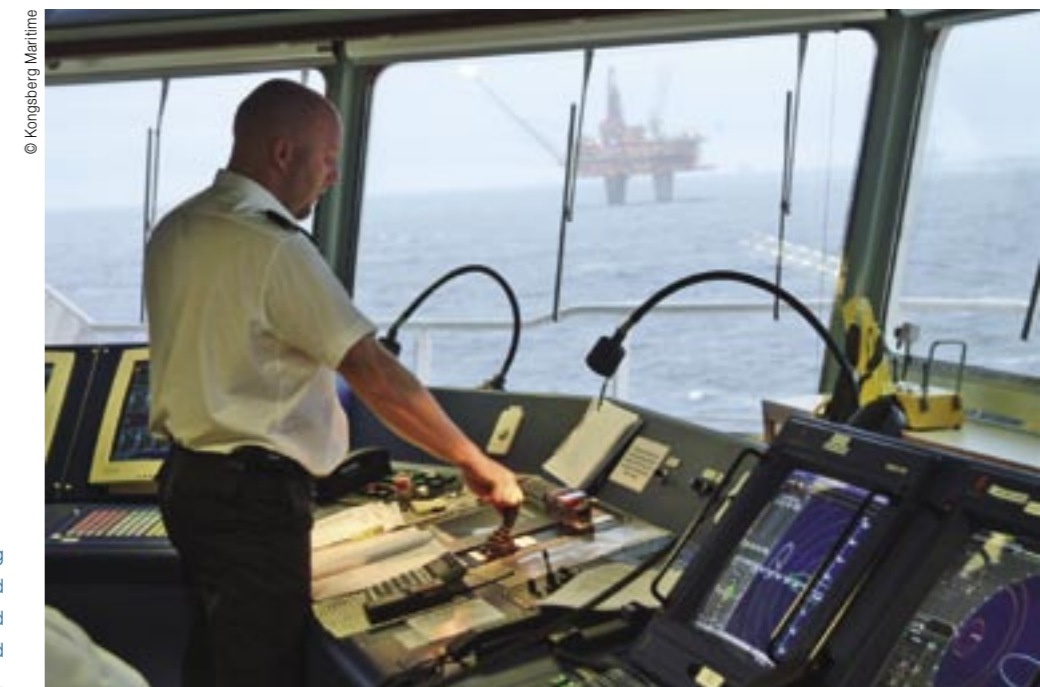

© Kongsberg Maritime

Kongsberg Maritime dynamic positioning systems keep vessels within specified position and heading limits, and are designed to minimize fuel consumption and wear and tear on the propulsion equipment.



Azimuth Thrusters

For DP systems to work properly in very rough seas, precision and raw power are needed to keep a ship in the desired position – attributes Rolls-Royce's azimuth thrusters have in spades.

Azimuth thrusters enable the propeller to rotate 360 degrees around a vertical axis so that the thrusters unit can perform both the propulsion and steering duties, and Rolls-Royce is one of the world's leading producers of these.

Whereas most azimuth thrusters that Rolls-Royce delivers for DP and low-speed manoeuvring systems are so-called pushing thrusters with the propeller located downstream of the gearhouse and vertical leg, Azipull is a pulling thruster with the propeller located upstream of the gearhouse.

Leif Vartdal of Rolls-Royce Marine's development division is one of the leaders behind the development of the Azipull azimuth thruster, and he is very pleased with the thruster's increasing market shares for different vessel types all over the world.

"A unique feature about this thruster compared to similar azimuth propulsion systems is that it can be fitted with both controllable and fixed-pitch propellers," Vartdal explains. This makes the Azipull very flexible with regard to the machinery systems it can be combined with.

"Because the water flows more uniformly into the propeller, the Azipull can be used for higher speed and provide higher efficiency compared to the pushing thrusters," he says, adding that the Azipull system has demonstrated a fuel cost saving of about 16% in an instance in which an Azipull arrangement was retrofitted to a vessel that originally was equipped with ordinary azimuth thrusters.

The clean propeller inflow is not only beneficial for propulsion efficiency – it is also good for reducing propeller-induced noise and vibration. "This is important for comfort, especially on cruise ships," he says.

The prototype of the Azipull was developed for a fast car/passenger ferry, but Rolls-Royce has delivered and on order around 150 Azipull systems for ships worldwide in three years, including offshore vessels, tankers, naval support and cruise/passenger ships.

Maritime Arctic Competence

Due to the special conditions characterizing the Arctic environment, the Norwegian Shipowners' Association (NSA) and the Norwegian Maritime Forum North have emphasized awareness of the challenges of operating in this area. As the host of the northernmost university in the world (69° N latitude), it was natural that Tromsø and the city's Tromsø University College was

given the lead role in the Maritime Arctic Competence (MAC) programme, which got underway in the fall of 2006.

"Through the education of personnel, we want to contribute to the safe operation of ships and offshore installation in the Arctic areas," says University College programme dean Hans Petter Kvaal, adding that many of the lectures will take place in English in order to facilitate international students.

Northern Norway and the surrounding waters have seen a dramatic increase in maritime activity over the last few years, and operative and administrative shipping personnel need to be aware of the specific concerns facing shipping in the extreme north. "Students joining this programme have broad experience in the operative and administrative branches of Norwegian shipping, but we will also depend on comprehensive academic competence," says Kvaal.

Therefore MAC has support from the Norwegian Polar Institute, the Norwegian Meteorological Institute, research foundation SINTEF, the University of



© Kongsberg Maritime

Kongsberg Maritime and Rolls-Royce dynamic positioning systems help modern vessels operate in precise and constant positions in extreme conditions.

Tromsø, Det Norske Veritas and the Norwegian Coast Guard to mention a few institutions.

Because of the broad expertise of the students joining the course, Kvaal believes MAC will be a unique centre of expertise contributing to knowledge exchange between the industry and academia. "Our challenge is to coordinate the experience coming from all of the different companies, research and education institutions as well as public administration, but I am confident that this will be an important centre of Arctic competence," Kvaal says.

Surveillance in Arctic Surroundings

Manoeuvring technologically complicated vessels in rough and cold waters, captains need to be constantly updated of potential dangers to their ships, such as icebergs, other ships and offshore installations adrift.

The Norwegian company Kongsberg Norcontrol IT is one of the world's leading companies in Vessel Traffic Management and Information Systems (VTMIS), Vessel Traffic Services (VTS) and Automatic Identification Systems (AIS). VTS systems utilize radar, closed-circuit television, VHF radiotelephony and AIS to make shipping as secure as possible.

In January 2007 a new VTMIS will be delivered to the Norwegian Coastal Administration, and will be located in Vardø. "One of the main tasks for the new

VTMIS in Vardø, which is most likely also the northernmost VTMIS in the world, will be to keep real-time track of the numerous tankers which transport oil from the Russian fields along the sensitive coast of Norway," says Kongsberg Norcontrol IT marketing manager Hilde P. Aarseth Krøgenes.

"In the event of an oil spill, we have technology in the Kongsberg Group which can help identify the ship responsible through satellite images and AIS. There are systems to predict and monitor the development of the spill, and our systems can be used for coordinating resources in connection with an oil spill and to keep other ships out of the operations area," she says.

With increasing traffic in the Barents and Norwegian Seas, international ships not prepared for rough Norwegian conditions can be an environmental hazard for a fragile Arctic environment, and therefore surveillance and early warning systems are vital.

In the Hibernia petroleum field located in the ice-cold and rough North Atlantic Ocean, approximately 315 kilometres southeast of St. John's, Newfoundland, Canada, the oil industry takes advantage of Norcontrol's

The Norwegian Coast Guard is an active participant in the newly started Maritime Arctic Competence (MAC) programme at Tromsø University College. Here, one of the Coast Guard's Lynx helicopters – stationed onboard the KV *Nordkapp* when not in flight – is transporting fuel to the depot at Hopen island in Svalbard, 76° N latitude.

systems in order to increase security. "Our systems can also detect icebergs and warn about collision threats. At the Hibernia field our customer uses these systems to protect their installations," Aarseth Krøgenes says.

"Barents Onscreen"

Surveillance of the Arctic areas is also important for the industry players, research institutions and the NSA. Therefore, the project *Barents på skjerm* ("Barents Onscreen") is important for the Arctic strategy for the Norwegian government. The goal of the project is to establish operational surveillance systems processing information through a digital service about such diverse aspects as ice, oil pollution, algae, shipping lanes and harbours. Safety in the north is very important for Norway, and is an issue that the Norwegian Minister of Foreign Affairs, Jonas Gahr Støre, has taken an active role in promoting.

"Barents Onscreen is an interesting concept and may become a tool in the surveillance of the High North and in promoting secure and sustainable shipping in the Arctic areas," says Gahr Støre.



© Norwegian Coast Guard

designed for success



By Dean Clark

Looking at the numbers, you wouldn't predict it. A country with only 0.1% of the world's population wouldn't be expected to rank among the world leaders in the shipping industry. But, thanks in part to creative thinking in maritime design, building and ownership techniques, Norway has managed to claim a nearly 5% share of the world's commercial shipping. The nation holds particularly strong positions in oil tankers, chemical tankers, and LNG and offshore ships.

The 90,000 people who work in Norway's maritime industry include highly skilled experts in all aspects of the field. Their experience has helped create a robust and promising outlook for the sector, as reported by the Norwegian Shipowners' Association's third-quarter report for 2006. The figures show that the number of vessels ordered by Norway's shipowners has greatly increased, with the majority of contracts going to domestic yards. This reflects the trend of the past four quarters – an overall 42% increase in ship orders.

Engineering Feat of the Year
Innovation clearly drives the strong growth in the sector, and one of the leaders in new maritime concepts is Ulstein Design. In fact, the company's radical inverted-bow concept, the X-Bow, was honoured as Norway's "Engineering Feat of the Year" at the end of 2005 by trade publication *Teknisk Ukeblad*.

Fresh thinking at the company led to the idea of combining a raised hull with a new bow shape that would increase wave contact. The result is the X-Bow, which has been praised as a revolutionary design that manages to achieve greater crew comfort and safety while lowering fuel consumption and increasing vessel speed.

Senior hydrodynamic designer Øyvind Karnsvag told *marinenorway.com* what sets this new design apart, "The Ulstein X-Bow is completely different to traditional vessels. The bow inclines backwards and the hull has been significantly raised, while at the same time it tolerates submersion." The marketplace success of the X-Bow and other innovations has helped Ulstein build up a strong order reserve of approximately NOK 3 billion as of fall 2006.

The Bourbon Orca – Promise Fulfilled

Bourbon Offshore worked with Ulstein and systems expert ODIM to realize the latest vision of a service boat with the X-Bow design. The new vessel, the *Bourbon Orca*, was launched in the summer of 2006 and has since been named "Ship of the Year" by the Norwegian trade publication *Skipsrevyen*. "Not only does the vessel fulfil all the criteria for being highly innovative, but she is also built on proven competence and her unique design adds value to the shipping industry," said publisher Asle Strønen at the *Skipsrevyen* award ceremony.

The awards jury cited *Orca's* stability, fluidity, manoeuvrability, safety systems, and significant environmental

improvements, such as the craft's diesel-electric propulsion, which, together with the new hull design, creates far fewer emissions of gas and toxics than traditional vessels.

New Tools for New Challenges

New maritime solutions often call for new tools, and Rolls-Royce Marine is in the forefront of developing valuable techniques to apply to its extensive marine design activities.

Computational Fluid Dynamics (CFD) is being used and further developed by the company to determine resistance in a seaway and to predict ship motions. This will help Rolls-Royce to find ways to reduce wave-making resistance for vessels in all kinds of different sea conditions.

The company is gathering data from existing offshore vessels to aid its CFD design process – using information gathered from wave-rider buoys and existing UT-series vessels to calculate how to create future ships with roll reduction, create new ideas for hull forms and explore promising deck/superstructure arrangements.

Offshore with an Octopus

Putting advanced research tools like CFD to work, Rolls-Royce Maritime has garnered wide international attention for the new, highly advanced *Olympic Octopus* designed for Olympic Shipping of Norway. It is one of the world's most advanced offshore vessels, embodying the latest thinking in offshore anchor handling.

The *Octopus* carries an efficient hull (to reduce fuel consumption), increased new safety equipment, and improved living conditions with reduced noise and vibration. For ease of operation, the vessel features simplified control systems, and refined Bergen-B series main engines, which provide more power and reduced emissions.

Anders Almstad, president of Rolls-Royce's offshore sector operations, has said the *Octopus* sets "a standard for the future in terms of environment and safety." In addition, the ship "is the first to use three important new Rolls-Royce product developments – equipment for safer deck

operations, the company's own dynamic positioning system and rim driver thruster technology."

All-Time High for Deep-Sea Vessels

As indicated by the development of the *Octopus*, the market for supply ships and other offshore service vessels is at an all-time high. One of the leaders in this field is Norwegian shipowner Olympic.

An important part of the future for the firm is submersible, remote-controlled vessels. The company feels that tomorrow's value lies in ships adapted to function as oil installations move from surface to seabed operations. "We aim to offer the oil companies vessels that meet their future requirements, not their past ones," wrote Stig Remøy of Olympic Shipping on the company's website.

A leading development in this niche is Olympic's UT 712 L, which is currently under construction. Features will include a full range of new Rolls-Royce offshore solutions, including systems for easier,

© Ulstein Group



Skipsrevyen's 2006 "Ship of the Year", the *Bourbon Orca*, features Ulstein's X-Bow design and has won top honours for stability, fluidity and environmental performance.

© Rolls-Royce/Harald Valderhaug



Olympic Shipping and Rolls-Royce Maritime collaborated to create the *Olympic Octopus*, an advanced anchor-handling vessel equipped with cutting-edge safety and performance systems.



safer deck work, DP2 dynamic positioning and a rim drive electric tunnel thruster. The cutting-edge ship will be built at Aker Yards at Soviknes.

Building for the World

The new Olympic vessel is just one of many projects underway at Aker Yards. One of the world's largest shipbuilders, Aker is an international group focusing on sophisticated vessels in the areas of cruise and ferries, merchant, and offshore and specialized vessels. With 17 yards in Norway and six other countries, the company has some 20,000 employees.

The size of Oslo-based Aker Yards has given it the scope to take on enormous projects, such as a recent contract signed with Stena of Sweden to build the world's largest ferries. The new ships will be 240 metres long and 32 metres wide, with 5,500 metres in trailer lanes and 700-metre car lanes of vehicle space. Passenger capacity will be 1,200 and service speed will reach 22 knots.

Leading the Way with LNG PSVs

Eidsvik Offshore is building the third in a series of new platform supply vessels (PSVs) that are fuelled by natural gas. Norwegian energy heavyweight Statoil

awarded the contract to Eidsvik with a focus on replacing vessels in its fleet currently powered by diesel marine fuel. The new LNG-powered ships will achieve a 28% reduction in CO₂ emissions with considerably less NOx output than the diesel vessels. With an eye towards future energy sources, the new technology on the LNG PSVs will also allow for the testing of fuel-cell propulsion.

Green Anchor Handling

Six large and environmentally friendly anchor handling vessels, designed by Vik-Sandvik, are being produced by Kleven Verft in Ulsteinvik. The work is being done under contract with Siem Offshore Inc of Kristiansand. Siem also holds an option for another six vessels.

The ships are sophisticated anchor handling vessels, 91 metres long, with 22-metre beams and engine power of 19,000 kW (28,000 Hk). The combination of environmental friendly design and large capacity helps these craft to be especially well suited for North Sea operations. A key to this kind of performance is the vessel's reinforced hull for work in icy conditions, and preparation for A-frame and ROV garage works.

Propelling Growth with High-Tech

Charting a new course for propeller technology on platform supply boats, Østensjø Rederi's new vessel, the *Edda Fram*, represents a breakthrough. She is the first offshore vessel fitted with Voith-Schneider type propellers, which provide roll stabilization. In addition, the vessel is fitted with eight integrated drill cutting and special purpose tanks which are able to provide flexible use for different cargoes.

Car Transport in High Gear

Norwegian/Swedish firm Wallenius Wilhelmsen Logistics is one of the world leaders in the car transport sector and is increasingly being recognized as a global standard-bearer for quality and performance. The firm was recently awarded the "Quest for Quality" award by the US trade publication *Logistics Management*. Readers voted Wallenius Wilhelmsen Logistics as overall winner in the publication's ocean carrier category for delivering the fastest and most reliable service.

© Wallenius Wilhelmsen Logistics



Wallenius Wilhelmsen Logistics operates the *Toronto* and other advanced ships for auto and truck transport clients worldwide.

the research council of norway

The Research Council of Norway offers project support to companies that invest in innovation through research and development. Industry projects are financed via the tax deduction scheme SkatteFUNN and within research programmes such as the User-driven Research-based Innovation programme (BIA). Long-term research projects are funded through the Centres for Research-Driven Innovation. Project support also can be found in thematic programmes such as MAROFF and Industrial Transport & ITS.

MAROFF – Increased Maritime Focus

MAROFF supports the Norwegian maritime cluster's international competitiveness through projects involving collaboration with customers and suppliers internationally.

The programme focuses its investment on innovation areas with the following objectives:

- Highly reliable maritime transport of passengers and goods as the most attractive transport alternative in terms of efficiency, economy and environmental friendliness
- Improved production and marine transport of fish contributing to added value for the Norwegian seafood industry
- The value chain for gas from well to market that cannot be reached by pipeline through innovative solutions for ship transport
- Dynamic shipbuilding and shipping operations by way of modularization and new design and building techniques
- Increase knowledge on effective exploitation of knowledge and company organization in a time when ICT and globalization of the economy provide new opportunities for operating in networks

Ongoing Research Council projects include topics as diverse as a market analysis for ship's gear, deepwater marine operations, and an energy-efficient, all-electric ship.

For more information, visit www.rcn.no/maroff

Industrial Transport & ITS (intelligent transport systems)

The programme supports industry, users and public authorities in gaining relevant knowledge and expertise within the following themes:

- Reduction of transportation costs for industry
- The movement of goods from roads to maritime and rail transport
- Smarter transport that addresses security, environmental needs and efficiency

For more information, visit www.rcn.no/transport

The Research Council of Norway is a strategic body for Norwegian research run under the auspices of the Ministry of Education and Research. The Research Council develops research policy based on guidelines from the Norwegian government and the Norwegian Parliament. Activities in the Research Council span financing basic research to applied research and innovation-related activities. In 2006, the Research Council administrated some €665 million, financed by 16 ministries.

For more information, visit www.rcn.no/industry

 **The Research Council of Norway**
Stensberggata 26
PO Box 2700 St. Hanshaugen
NO-0131 Oslo, Norway
Tel: +47 22 03 70 00
Fax: +47 22 03 70 01
Website: www.rcn.no



© Svein Grønvdal/NN/Samfoto

marine technology

frontrunners



by Nancy Bazilchuk

It seemed a fitting nod to Norway's maritime history: one of the first ships ever to be tested in the Norwegian Marine Technology Research Institute's (MARINTEK) Ship Model Basin was a model of the Viking Gokstad ship, from 970. That inaugural test, in 1939, and the basin's 2,500 subsequent tests to the present day are just one example of Norway's tried-and-true approach to shipping research and development.

Hands-on experiments, in some of the most advanced ship testing facilities on the planet, coupled with practical experience and world-class computational modelling, place Norway among the world's leaders in developing innovative approaches to ship design and handling, and solving the environmental and technical challenges that arise at sea.

The Norwegian government has put a premium on funding maritime research through research programmes such as MARUT, which is a large cooperative effort between the government and industry initiated in 2004 by the Ministry of Trade and Industry. MARUT serves as an umbrella organization to coordinate research efforts funded through the Research Council of Norway's MAROFF programme, along with Innovation Norway's Maritime Development programme. Industry also contributes to the groundswell of research overall by financing efforts through the country's universities, as well as research institutes such as MARINTEK.

There's good reason for this broad base of support. Dr. Mike Howse, Rolls-Royce director of engineering and technology, put it this way when he opened a Rolls-Royce University Technology Centre at the Norwegian University of Science and Technology (NTNU) and MARINTEK in May 2005. "You are the best in the world in marine technology," he told the crowd at the opening ceremony. "There are really good people here to carry out the research."

Little Tiny Bubbles & Big Tanks

As head of the Rolls-Royce University Technology Centre at NTNU, Sverre Steen is preoccupied with tiny little bubbles. These are no ordinary bubbles, however: they're bubbles of low pressure that form around parts of a spinning propeller's blade, which literally implode with a force sufficient to damage the blade. Steen, who is also a professor at NTNU's Faculty of Engineering Science and Technology, Department of Marine Technology, is also looking at what happens to propellers when rough seas toss ships up and down,

exposing propellers to the air. These stresses and strains can harm propellers, but more often they're the source of great inefficiencies in operating ships – inefficiencies that Steen's sponsor, Rolls-Royce, is hoping he and other researchers can curb.

Steen's work is made easier by the Ship and Ocean Laboratory facilities at MARINTEK, the marine research arm of SINTEF, Scandinavia's largest independent research institution. MARINTEK is also a cooperator in the UTC, which is properly called the "Performance in a Seaway" UTC. The lab's world-class facilities are

comprised of a 280-metre long towing tank, a 50- by 80-metre ocean basin with a depth adjustable to 10 metres, a cavitation tunnel and a sloshing tank. These tools allow scientists and engineers to build scale models to test their ideas, and expand on the predictions and simulations that computer models can offer.

MARINTEK's expertise and cooperative projects extend throughout the maritime shipping and logistics chain. Among its dozens of projects, the group is working with Farstad Shipping to develop an offshore simulation centre in Ålesund, on the development of gas-driven fuel engines for LNG carriers in cooperation with Rolls-Royce Marine and Wärtsilä, and on a project with ExxonMobil to reduce the problems posed by the sloshing of LNG in membrane tanks.

"Our testing facilities give us a great opportunity to get close to our customers, pinpoint areas for improvement, and propose projects," Egil Rensvik, MARINTEK special advisor, said in a recent Nor-Shipping newsletter.

Funding the Future

Ask Sigurd Falch, head of the Research Council of Norway's MAROFF programme,

Norwegian shipping research and development is focused on improving the design, efficiency and service provided by the Norwegian shipping industry to its customers. The *Stril Odin* is an example of a specialized offshore vessel that is typical of the Norwegian fleet. It was delivered by Aker Yards to Simon Møkster Shipping in 2006.

why it's so important for the Norwegian government to support research and he's got a ready answer. "One of the reasons that Norway is so strong in this sector is that we have a well-established research community," he said. "You can attract good people and you can educate good people, but you have to have good research at the universities where you are educating these people."

MAROFF, which stands for Maritime Activities and Offshore Operations, has as its goal the support of innovative industry-related research projects, with roughly NOK 64 million handed out to 13 projects in the last round of financing in May 2006. The overall budget for MAROFF for 2007 is proposed at NOK 90 million, Falch said.

Just what kind of work does MAROFF support? DNV Industry in Høvik outside Oslo, received funding to develop the use of an adhesive polymer film in place of anti-fouling paint, while AKVAsmart of Bryne was funded to develop and implement a process control system for the aquaculture industry. SINTEF Fisheries and Aquaculture was funded to

develop the optimization of bottom trawl gear in terms of energy consumption, while a new international training and pre-simulation concept targeted to Arctic marine operations will be developed by the Ship Manoeuvring Simulator Centre of Trondheim.

Marine pollution is also a focus. The development of technologies to reduce nitrogen oxide (NOx) emissions from ships may see a boost, if a recommendation to target NOK 20 million of MAROFF's 2007 budget and NOK 10 million of Innovation Norway's budget is approved. Worldwide, ships have generally fallen outside of traditional legislation to control air pollution, with the consequence that ship-related emissions have exceeded those from land-based sources. But NOx contributes to acid deposition, which can harm trees and fish, as well as overfertilization of the seas, which promotes harmful algae blooms.

MAROFF is a part of a larger cooperative effort called MARUT, which is overseen by a governing council composed of top leaders from industry and academia,

Researchers at Rolls-Royce's University Technology Centre at NTNU and MARINTEK are investigating how to further improve efficiencies for thrusters and propellers, particularly in rough seas. The Ulster Aquamaster azimuth thruster with contra-rotating propellers is shown here.

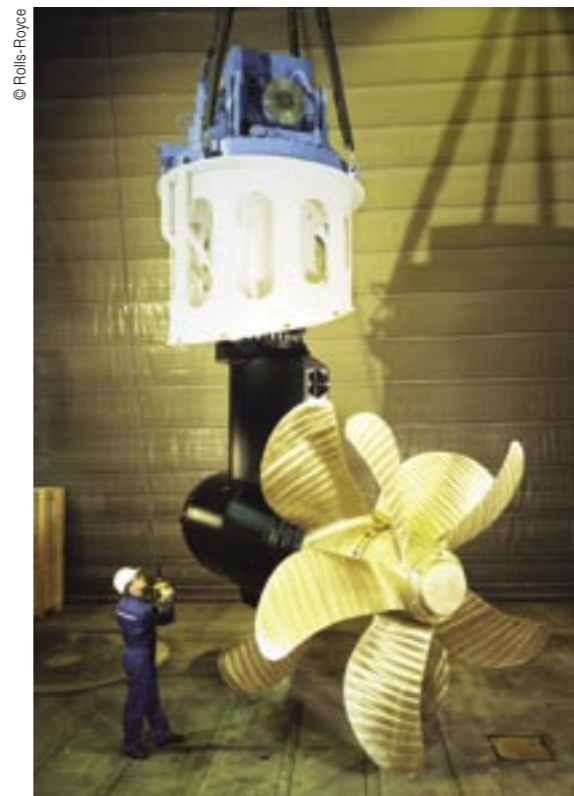

© Rolls-Royce



© Aker Yards



including Karl Erik Kjelstad, president and CEO of Aker Yards; Oddbjørn Eliassen, president of commercial operations for Rolls-Royce Marine; and Tor Svendsen, the chief operating officer of Det Norske Veritas (DNV). MARUT's governing council helps set overall direction for different funding efforts, including MAROFF and research funded through Innovation Norway.

Protecting the Environment

Norway's shipping industry has also worked hard to push for environmentally friendly innovations. Five new LNG-driven ferries, designed by LMG Marin of Bergen and built by Aker Yards will begin operating on Norwegian fjords in 2007. The ships will emit 25 percent less CO₂ and 83 percent less oxides of nitrogen than conventionally powered diesel ferries, and are free of sulphur and particle emissions.

Shipping carries more than 90 percent of the world's trade – but it can also carry unwanted hitchhikers in ship water ballast. Invasive species carried by ships have the potential to devastate fisheries and harm tourism, as has happened in the Black Sea with the accidental introduction of a jellyfish that destroyed the anchovy fishery. A number of Norwegian companies

have worked to develop cutting-edge technology to treat ballast water to eliminate unwanted organisms, including OceanSaver of Høvik and Knutsen OAS Shipping of Haugesund.

DNV was founded in 1864 as a ship classification society, but has expanded its expertise to cover identification, assessment and consultation on managing risk. What most people don't realize is that DNV is a major strategic research player, spending nearly NOK 100 million per year on developing new knowledge and facilitating the introduction of novel, innovative transport designs, says Per Olaf Brett, DNV Research project director.

DNV is currently working in three broad areas of marine transport research: safe transport, effective transport and green transport. For example, DNV has worked with a consortium of companies under the umbrella of the Research Council of Norway to develop ways to use a ship's Automatic Identification System (AIS) to identify ships potentially at risk of causing oil spills or accidents in fragile northern areas.

Another DNV project has been called LOGBASED, for logistics-based design. The goal of the project has been to develop a new kind of ship design methodology that allows a ship to be tailored to a specific trade route. In a blend of the managerial, engineering and commercial worlds, LOGBASED has helped develop methods for identifying and implementing logistic requirements and uncertainty in ship design, as well as improving our understanding of risk identification, evaluation and mitigation in operations of logistic systems. These methods also result in an overall improvement in design approach, Brett said.

Brett says that DNV always pairs with industry in conducting its research, as a way to understand business demands and enable DNV to service businesses of the future. "We follow the real problems and challenges of the world," he said. "We go with the problems and the flow. We try to be dynamic and fluid in the sense of where the world is taking us, we want to be a part of it."

Norwegian shipping R&D achievements include the introduction of environmentally friendly LNG-driven ferries. *Bergensfjord* is a LNG-powered car- and passenger ferry that was delivered by Aker Yards, Søviknes in November 2006, and is the first in a series of five ferries to be delivered to Norway's Fjord1 Nordvestlandske.

© Aker Yards



nor-shipping 2007 – "join the leaders"

Nordic shipowners, yards, suppliers and service providers strive to stay at the cutting edge of the industry. Leading technologies, companies and people converge at Nor-Shipping. Come to Oslo June 12–15, 2007 and join the leaders.

Stand still in the maritime business and you'll quickly disappear. Companies in the Norwegian shipping cluster and the broader Nordic market drive change in the industry as they seek to remain ahead of stiff competition from both east and west. This creates an attractive hub for companies further afield to share knowledge, establish contacts and make partnerships.

"There's an atmosphere of increased risk-taking in the shipping industry in Northern Europe. A combination of skillful personnel and capital willing to support innovation in the industry leads to new products and business models, which are adopted later in other markets," says Nor-Shipping director Tollef Schiander.

This atmosphere pervades the Nor-Shipping exhibition, where the industry's leaders gather to discuss new ideas, products, trends and developments in the

business. The Leading Voices conference, launched first in 2005 with speakers like Andreas Sohlen Pao of Worldwide Shipping and Bjørn Møller of BP Shipping, opens Nor-Shipping's exhibition and features opinions and statements from some of the industry's most influential figures.

For Nor-Shipping 2007, the theme is "Join the Leaders"; this exhibition draws leading technologies, businesses and individuals from throughout the Nordic region and beyond to partake in the leading maritime

event week. Virtual networking in this digital age has increased the significance of the hands-on networking and exchange of knowledge at Nor-Shipping.

"Join the Leaders" reflects the programme for Nor-Shipping 2007's affiliated conferences, in particular the Leading Voices conference, the Nor-Shipping newsletter and the website. Here you will find articles and opinions from leaders in the maritime industry. The Nor-Shipping team urges you to follow these developments and join them in Oslo for Nor-Shipping 2007.



For more information, please visit www.nor-shipping.com





compete when they have to, cooperate when they can

By Kristian Kahrs

A significant competitive edge for Norwegian shipping is the unique synergies emerging from a well-developed cooperation between all of the major players in the Norwegian maritime cluster. Oslo is an important international financial centre for shipping, and in the northwestern part of the country, the Møre cluster features an extraordinary closeness between the players – enabling projects to be implemented shortly after they have been designed on the drawing board.

Taking advantage of the continuous exchange of knowledge between shipowners, designers, equipment manufacturers, engineers and shipbuilders, the Ulstein Group is one of the world's most effective organizations in the implementation of shipping projects soon after the idea has been born. Ulstein and most of its subcontractors are located in the Møre cluster.

Implementing Ideas

"We are not very formal and theoretical. When we have a good idea, we implement it as soon as possible," says deputy CEO and director of market and business development of the Ulstein Group, Tore Ulstein.

One example of the rapid implementation of projects is the Ulstein AX104, an anchor handling tug supply vessel. Handling anchors in offshore installations can be very challenging in rough seas, so sufficient power in the most important areas is an absolute necessity. The AX104 is the first

anchor handling tug supply vessel with a diesel-electric propulsion system.

"This is important because it gives us a lot more flexibility. These ships are often in one location for a longer period of time, and with a diesel-electric system we are able to apply several diesel aggregates when we need full capacity," Ulstein explains.

And extreme power is truly needed to hold offshore installations in place. Winches have to be able to withstand pressure of 500 tonnes and the ship's bollard pull must be as much as 300 tonnes.

Ulstein is especially pleased with the ship's new hull shape. "Her bow is the reverse of a conventional bow, leaning backwards instead of forwards, and thus, the vessel cleaves the waves, significantly reducing noise and vibration," he explains, adding that the third AX104 innovation is an entirely new anchor handling system, including a new stern ramp, moveable towing

pin, cranes mounted on cargo rails and equipment for catching the pennant wire.

"The AX104 started as a vision, and then developed into a concept design. The cooperation in the Norwegian maritime cluster has also been an important part in turning this vision into reality," says Ulstein. The market for offshore vessels has never been better, and while Ulstein is very aware that such times can't last forever, he believes the Norwegian maritime cluster will continue to give the company a competitive edge, "We have to intensify our efforts to become more international, and at the moment we are building vessels in Brazil and China. The national market is vulnerable, and therefore we need more strings to play on."

Within the Møre Cluster, the competition is hard, but not too hard. It is a strong cluster because of the cooperation. "We cooperate when we can and compete when we have to," says Ulstein.

Investing in Human Capital

Rolls-Royce Marine, one of the world's leading marine systems companies, has more departments and production facilities in Norway than in any other country – most of them situated in the Møre cluster. Consequently, all companies in the Norwegian maritime cluster, whether in Møre or elsewhere, have a common interest in investing in human capital. While these have been heady times for Norwegian shipping – and for the Norwegian economy as a whole – this also means intense competition in order to recruit the best people. Therefore, education is an important element in the maritime cluster.

Rolls-Royce Marine director of research and technology, Rune Garen, is very familiar with this issue. "We have to involve ourselves in the proper mechanisms to recruit the human capital needed for advanced shipping applications. It is unfortunate when we have to turn down business because we don't have enough competent people," Garen says.

As one of the major players in ship design and ship's gear in Norway, British-owned Rolls-Royce invests heavily in research and technology. This results in demands to Norwegian universities and colleges, and thus, Norwegian students gain specific skills needed by the industry.

Rolls-Royce has also formalized its cooperation with the Norwegian University of Science and Technology (NTNU) and the

Norwegian Marine Technology Research Institute (MARINTEK) located in Trondheim, a central city in the Norwegian maritime cluster. Together with Ålesund University College, located close to Rolls-Royce Marine's headquarters in Ulsteinvik, Møre, these universities and research institutions provide the industry with exactly the expertise demanded in a competitive environment.

"Rolls-Royce chooses universities and institutions worldwide with potential areas important for the company. The skills acquired in educational institutions are closely connected with a system of innovation, and we want the students to think locally and act globally," Garen says.

Some years ago, capital to finance shipping projects was sometimes a problem, but now the challenge is to find the proper human capital. However, Garen is optimistic that Norwegian shipping will continue to recruit the best professionals and the brightest heads for the further development of the industry.

"Some Norwegians think we are a nation of peacemakers. This is not true. We are a small, insignificant nation, but when it comes to shipping, we are a maritime superpower. The world listens to us," he says.

International Recruitment

Even with the focus on maritime training and education, the Norwegian shipping industry cannot depend solely on domestic competence in order to handle all of the challenges from an increasingly technologically advanced industry.

Tor Espedal is the vice president of the Norwegian division of Subsea 7, one of the world's leading subsea engineering and construction contractors. Together with the Norwegian Shipowners' Association (NSA), Odfjell Drilling and Acergy, the company wants to recruit 50–60 Russian engineers annually to several shipowners and offshore companies. "We don't have



© Ulstein Group



In the Møre cluster in northwestern Norway, there are short distances between the drawing board and the implementation of shipping projects. One example of this is the Ulstein AX104 anchor handling tug supply vessel.



enough engineers, and Russia has a good reputation when it comes to educating students in mathematics and science,” he says.

Norwegian ships also depend on international experts to operate ships, and the Philippines, Russia, China and the Baltic countries are vital in providing the professionals needed. Since 1999, 1,200 Chinese sailors have been recruited and educated through the China Coordination Council for Overseas Seamen Employment. And the Philippines is the biggest supplier of sailors to Norwegian ships, with recruitment stemming from the Norwegian Training Centre – Manila.

Centre of Expertise

To take advantage of all of the aspects of the Norwegian maritime cluster, the Norwegian government have supported the start-up of the Norwegian Centre of Expertise – Maritime. Because the Møre region has the most complete maritime cluster in Norway, the authorities chose to locate the core administration in Ålesund, the largest city in Møre. Annually, the Møre cluster generates about NOK 25 billion, but in ten years the goal is to quadruple the amount to NOK 100 billion.

The director of the Centre of Expertise, Per Erik Dalen, is aware that this is a very ambitious goal, but doesn't feel that

it's out of the realm of possibility. “It is a realistic goal. Our vessels are increasingly advanced, travelling in deeper and colder waters and operating in extreme subsea conditions. We started off with fishing boats, but now we are talking about advanced vessels for the offshore industry,” says Dalen.

The centre opened in the fall of 2006. “The companies are the experts, and here there are people who are dedicated to serving them. Furthermore, we will give them significant academic competence,” he adds.

The goal of the expertise centre is to connect the various players in order to ensure the foundation for cooperation between the companies and make sure that shipping projects have enough capital in the different phases of business development. “We want to be active in marketing our cluster and the general activity so that it can be visible for all relevant parties,” Dalen says.

Norwegian Minister of Trade and Industry Dag Terje Andersen was also present at the opening of the centre, and he is proud and excited that the Møre cluster is an international leader and an example to others. “The northwestern corner of Norway is a centre for innovative and world-leading shipping companies. You have created a complete cluster,” Andersen said, emphasizing the advantage of a close cooperation.

Oslo Maritime Network

Serving as the Norwegian Minister of Trade and Industry from 2001 to 2004, Ansgar Gabrielsen developed and still has a passion for shipping. The former minister initiated the Oslo Maritime Network in the fall of 2006. Gabrielsen wants to inspire the shipping industry in the Oslo region to pull together, and to realize that it has tremendous competence – without necessarily needing to recruit professionals from far away.



A model of the UT 767 CD oil well intervention vessel at the MARINTEK test facilities in Trondheim. The ship's design makes it possible to extract more oil and gas from wells in a cheaper, safer and simpler way.

However, Gabrielsen doesn't see a contradiction between strong shipping clusters in the Oslo region, Møre, southwest Norway, western Norway and other maritime environments in Norway. He views all of the areas as one big cluster.

In the same way as Møre, Oslo has its own advantages. “Oslo has one of the world's most complete clusters, except for the shipbuilders,” says Gabrielsen from his office at the NSA. “We have big shipowners, ship finance institutions, shipbrokers and classification companies. Furthermore, large parts of the legal and educational institutions are located in Oslo.”

In Oslo, there are about 1,000 companies involved in shipping in one way or another, and Gabrielsen wants the Oslo Maritime Network to increase the awareness about the importance of the maritime-related companies in Oslo in both in the professional and general population segments.

“We don't want to build a huge administration, but we want to encourage innovation between traditional maritime companies and companies not immediately connected with the maritime industries.

We can take advantage of some important synergies here,” he says.

Gabrielsen admits that other areas in Norway have been better able to take advantage of these synergies. “The maritime industry has been more fragmented in Oslo than in other parts of Norway, but we want to connect companies together in order to help them discover their mutual dependence on each other,” he says.

Financing Global Shipping

The world's shipping markets need reliable and secure funding, and Norwegian banks and financial institutions play a vital role in financing, insuring and advising on global shipping activities.

Norway has two heavyweights when it comes to ship financing. The Nordic bank Nordea, with shipping headquarters in Oslo, has global shipping commitments of \$12.5 billion, while Norway's largest bank – DnB NOR – has corresponding figures of \$11 billion. These tallies place the two banks alongside Citibank as the three largest ship finance institutions in the world.

“Combined, these two banks give a tremendous boost to the market,” says Carl E. Steen, head of Nordea's shipping, offshore and oil services division.

Even if the Norwegian stock market is small by global standards, the Oslo Stock Exchange is one of Europe's – and possibly the world's – leading stock exchanges for the shipping industry. “Norwegian shipping analysts are highly skilled, and they provide quality analysis of the individual companies and the different segments in the industry,” says Oslo Stock Exchange senior vice president Per Eikrem.

In addition to shipping finance, Norway is also one of the driving forces within marine insurance, represented by flagships Skuld and Gard. Combined, Norwegian insurance companies have about 15 percent of the global shipping insurance market. “Our workforce possesses a unique mix of expertise in marine insurance, energy insurance and claims handling, as well as a broad range of professional qualifications and practical experience,” says Gard CEO Claes Christian Isacson.

Norwegian Crown Prince Haakon opened the Offshore Simulator Centre at the Ålesund University College in 2005, a training centre that includes full-mission training in such areas as anchor handling. Farstad Shipping, Rolls-Royce Marine and MARINTEK are partners in the project.





norwegian shipping

confronts pollution

By Kristian Kahrs

The environment is a top priority for the Norwegian shipping industry. Therefore current initiatives include using fuel cell technology to bring about the possibility of ultra-clean ships, technology to clean ballast water, and the introduction of ship engines powered by liquefied natural gas (LNG) instead of conventional diesel engines.

LNG to Fuel Modern Ships

Using LNG to fuel modern ships has many advantages, and the technology is currently at use in five ferries in western Norway operated by Fjord1. Norwegian companies are involved in almost all aspects of the project – LMG Marin in Bergen is responsible for the design, the Norwegian division of Rolls-Royce Marine produced the engines, and the ships were built by Aker Yards in Brattvåg.

Geir Rise is the design manager at LMG Marin, and he is proud to present a new generation of vessels with highly reliable gas configuration, thrusters, main machinery and manoeuvring systems.

“Gas-electric LNG-fuelled ferries have high transport efficiency, are environmentally friendly, and have capacities arranged for today’s traffic and for estimated increases in transport volumes in the operation period,” Rise said, adding that safety levels are equal to or better than traditional diesel-fuelled ferries.

LMG Marin has carried out technical-economic analysis which concludes that LNG is a very economically favourable fuel for ferries, high-speed ships and other ships, especially when the price of oil is high.

Leif-Arne Skarbø is a project manager for the LNG ship engine project for Rolls-Royce Marine, and he sees a great potential for gas-fuelled ships in addition to ferries.

“At the moment we are in the commissioning phase, and we believe that this project is going to be a spearhead. We have many shipowners who are interested in this technology,” says Skarbø, who sees many potential markets. Supply vessels and production ships have already utilized the technology.

“We see great markets in the Baltic area, the English Channel, and the North Sea, and there is a lot of infrastructure in the Arctic Ocean with massive traffic and many ships not leaving the area,” Skarbø explains.

However, one challenge with LNG-fuelled ships is that they require a lot of volume for fuel. While some ship types have available

void spaces that can be utilized for LNG tanks, the logistics for LNG distribution are still in their early days.

“The environmental benefits of LNG ships are great. Pollution from gases like CO₂, sulphur and nitrogen oxide (NOx) will be dramatically reduced. CO₂ will be reduced by 25 percent,” Skarbø says. “There is no sulphur in LNG, and therefore shipowners avoid penalty taxation. Furthermore, by using these engines we reduce NOx by 90 percent and thus reduce the NOx tax by 90 percent.”

Microorganisms from Port to Port

In the world of global shipping, non-native aquatic organisms are easily transported from port to port in ships’ ballast water. It is therefore essential to make sure that water discharged from the ballast tanks is clean. The Norwegian company OceanSaver has developed a solution for this with its OceanSaver ballast water treatment system. The system won the prestigious “Protection of the Marine and Atmospheric Environment” Seatrade Award in April 2006 for its technology.

Stein Foss, managing director at OceanSaver, explains that the company’s system provides compliant ballast water treatment, and at the same time also offers efficient corrosion control and coating protection of the steel structure in the ballast tanks – providing a potential life extension for ships.

“Our system combines a number of physical processes exposing ballast water organisms to pressure differentials, causing the rupture and destruction of organisms’ cell membranes. This leaves the ballast water compliant with the stringent IMO Ballast Water Performance Standard and also deficient in oxygen – which significantly reduces the rate of corrosion,” Foss says.

Cleaning and maintaining ballast tanks has been a challenge, but Foss believes the maintenance costs will be dramatically reduced. Furthermore, for vessels to be safe, their structural integrity must be sustainable. “In order for the ship’s structure to be sustainable, it is necessary to protect the steel surfaces with coatings. The OceanSaver system prevents creep corrosion and protects the applied coatings – and thus structural integrity is maintained.”

“The fact that the system combines efficient ballast water treatment with reduced corrosion is a unique advantage. Reduced corrosion in ballast tanks alone provides great savings,” says Foss.

Ultra-Clean Ships

With increased oil prices, increased fuel costs is a great problem faced by shipowners in modern shipping. The “FellowSHIP” programme initiated by Det Norske Veritas (DNV) hones in on this predicament by integrating hybrid fuel cell systems with conventional power machinery run on gas.

Together with the companies Wärtsilä Automation Norway, Eidesvik Offshore, MTU CFC Solutions, Vik-Sandvik, Wallenius Marine and Wärtsilä Corporation, DNV is developing technology to help bring about ultra-clean ships.

DNV project coordinator Tomas Tronstad is proud to introduce technology that can dramatically reduce hazards from poisonous gases to the environment.

“The FellowSHIP technology will be up to 50 percent more efficient than today’s diesel power, while at the same time there will be no emissions of NOx, sulphur oxide (SOx) or particles. The CO₂ emissions are reduced by 50 percent compared to diesel engines run on oil,” he says.

Fuel cells differ from batteries in that they are designed for continuous replenishment of the reactants consumed; they produce electricity from an external supply of fuel and oxygen as opposed to the limited internal energy storage capacity of a battery.

“In a fuel cell, the absence of a combustion process, which otherwise would produce nitrous oxides and particles, allows for completely pollution-free conversion of energy,” Tronstad explains, adding that the technology is inherently silent and vibration free – as there are no moving parts except for supporting systems.

Plans include installing a 330 kW MCFC fuel cell onboard an offshore supply vessel in 2008. This will be the first fuel cell system developed for auxiliary and propulsion power to be placed onboard a merchant vessel, and there are great potential savings in utilizing this new technology.

“A DNV study of anticipated environmental requirements for ships in the future reveals that a fuel cell ship will see drastically reduced operating costs due to the introduction of incentive mechanisms for reducing air emissions,” Tronstad says.

The *Høegh Trooper* vehicle carrier was retrofitted with the OceanSaver ballast water treatment system. The treatment system won a Seatrade award in April 2006 for its technology.



© OceanSaver

The *Viking FellowSHIP* is a small-scale model powered by hydrogen and fuel cells. A full-scale demonstration of technology from the “FellowSHIP” programme is planned to be realized in 2008, using gas fuel.

© DNV Research



the thor heyerdahl award

Thor Heyerdahl and the Norwegian Shipowners' Association launched the award in June 1999. The purpose of the Thor Heyerdahl Award is to:

- **Contribute to an improvement of the global environment**
- **Promote the environmental benefits of shipping as a mode of transport to society as a whole**
- **Serve as an inspiration for implementing new, specific environmental measures**

The next winner will be announced in June 2007, at the Nor-Shipping international shipping conference and exhibition in Oslo, Norway.

Closing date for submitting proposals: March 1, 2007.



Thor Heyerdahl.

How to Qualify for the Award

- By carrying out or helping to carry out new environmental measures in the candidate's own operations that are not imposed on those operations by any government agency
- By developing new environmental measures that are feasible/financially sustainable. This will especially include measures that combine the interest of the environment with improved profitability

The committee will be international in its composition. The award consists of a statuette and a diploma.

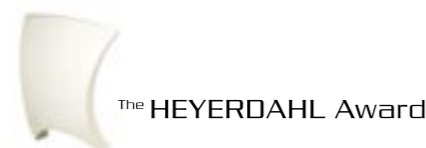

The Thor Heyerdahl International Maritime Environmental Award

PO Box 1452 Vika
NO-0116 Oslo, Norway
E-mail: mailbox@heyerdahlaward.com
Website: www.heyerdahlaward.com



The Heyerdahl prize is sculpted by the well-known Norwegian artist Nico Widerberg.

AC Marine

AC MARINE AS
PO Box 6120 Etterstad • NO-0602 Oslo, Norway
Tel: +47 23 20 75 00 • Fax: +47 23 20 75 01
E-mail: info@acmarine.no
Website: wwwno.acmarine.no



AC Marine AS is a world-leading engineering and system supplier of total heating, ventilation and air conditioning (HVAC) solutions, specializing in oil and gas and marine applications. Throughout the course of more than 40 years' experience in providing turnkey HVAC solutions to offshore installations and vessels worldwide, AC Marine has acquired a unique competence, which ensures solutions meeting the most stringent demands for comfort, safety and energy efficiency under all environmental conditions.

Qualified Service for the Entire Value Chain

AC Marine provides proven, reliable technology from major manufacturers combined with highly qualified services throughout the entire value chain – from concept studies and engineering to equipment supply, installation and after-sales service and support. Working closely with customers and suppliers, AC Marine provides system design, engineering, supply and commissioning of HVAC systems to all kinds of marine and offshore vessels and installations.

Large, complex HVAC projects in the offshore and marine industries are fraught with numerous challenges related to health and safety, logistics, economics, quality assurance and overall performance. AC Marine knows how to avoid the potential pitfalls of such projects, providing total HVAC solutions in a highly efficient and cost-effective manner. Implementing its broad expertise from the numerous HVAC disciplines and working in collaboration with sub-suppliers, AC Marine ensures

that all requirements and specifications are fulfilled. Through its centralized project administration, engineering, QA, logistics and system supply, the number of interfaces and potential error sources are reduced, and consistent QA/HSE is maintained throughout all project phases.

Snøhvit LNG Facility

The Snøhvit facility in northern Norway is but one example of the effectiveness of AC Marine's systems and proven expertise. AC Marine is the HVAC system supplier for all of the process system modules with the necessary airflow and correct temperature for Snøhvit, the first offshore development in the Barents Sea and the world's northernmost LNG project. Air handling units, fans, cooling machines, fire and gas dampers, heaters and local HVAC panels for the Snøhvit facility have all been designed and delivered by AC Marine. Equipment has been selected and procured from manufacturers all over Europe, while on-site supervisors ensure that all installation and construction are in the capable hands of AC Marine.

Worldwide Network

AC Marine's corporate headquarters are located in Oslo, Norway, and its main Service Office is based in Bergen, Norway. From these locations, the company carries out engineering services and coordinates global sales and service activities. Local sales, service and technical support is available directly through a worldwide network of regional offices and agents in the United States, Brazil, Nigeria, Singapore, South Korea, Iran, Denmark and Sweden.



Norwegian
Shipowners' Association

In cooperation with:





ALtech A.S

Valves & Process Equipment

ALTECH AS
 PO Box 35641 • NO-3007 Drammen, Norway
 Tel: +47 32 21 79 00 • Fax: +47 32 21 79 01
 E-mail: altech@altech.no • Website: www.altech.no

Altech AS was founded in 1996 and is located just outside of Oslo in the city of Drammen. An engineering and agency company, all of Altech's employees have a great deal of experience from the Norwegian and international valve markets. The company has developed a distribution network in the Nordic countries on behalf of the many manufacturers it represents.

Markets

The company exports complete valve packages and tailor-made valve control systems for the shipping industry and special valves for fish pumps, the latter supplied specifically to markets in Norway, Iceland and Chile.

Altech's specific products and systems include:

- Valve control systems – manual, electric, pneumatic and hydraulic
- Remote-controlled ballasting systems
- Remote-controlled cargo systems for crude, product and chemical carriers

Valve Series

Altech's product range features a number of various valve types from a range of suppliers. Knifegate valves are specially designed for fish pumps and ideal for abrasive media. Altech distributes knifegate valves supplied by the Spanish company CYL, which is located in northern Spain and is an experienced knifegate valve designer and manufacturer.

Altech AS also represents the Spanish centric soft-seated butterfly valve manufacturer Sigeval SA in the Nordic countries. Sigeval is known for its high-quality products, flexibility and quick

deliveries. In addition to standard ship valves, Altech's other valve types for the shipping market include HPBF valves and double-eccentric butterfly valves, basic components onboard a tanker or in a hydroelectric plant.

Altech AS cooperates worldwide with several other system designers within such fields as shipping, fisheries, firefighting and hydroelectric power.



Barwil Unitor Ships Service

BARWIL UNITOR SHIPS SERVICE
 PO Box 33 • NO-1324 Lysaker, Norway
 Tel: +47 67 58 45 50 • Fax: +47 67 58 45 70
 E-mail: barwilunitor.info@wilhelmsen.com
 Website: www.barwilunitor.com

Barwil Unitor comprises one of the world's leading maritime services networks, with the capability to service 2,200 ports in 116 countries. The company's focus is to deliver improved vessel operating efficiency to the merchant fleet. In 2005 Barwil Unitor made 175,000 product deliveries to 16,400 vessels and handled 51,000 port agency calls.

Recognized & Trusted Leading Brands

Barwil Unitor offers a comprehensive range of standardized services and products, backed up by a global service organization:

- Barwil port agency services
- Barwil liner logistics
- Unitor safety equipment and service
- Unitor marine chemicals
- Unitor refrigeration services
- Unitor cylinders, gases and gas distribution systems
- Unitor welding equipment and consumables
- Unitor surface application equipment
- Unitor marine spare centres

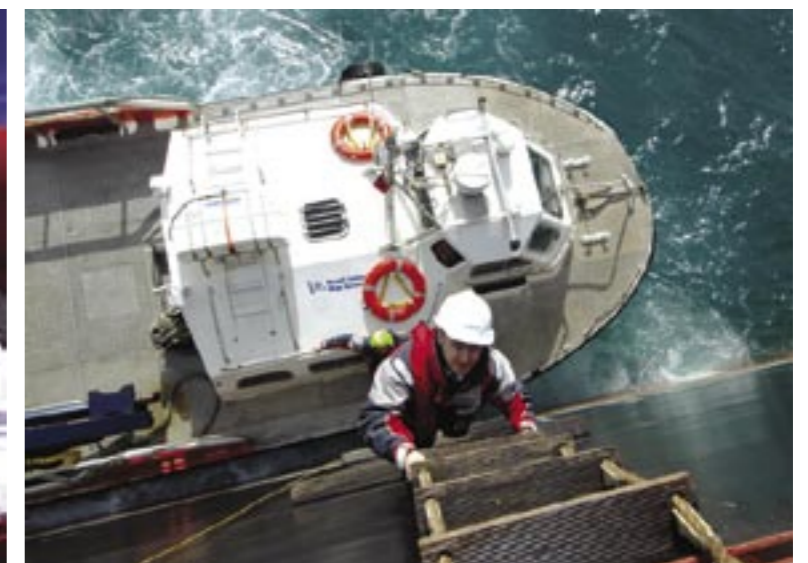

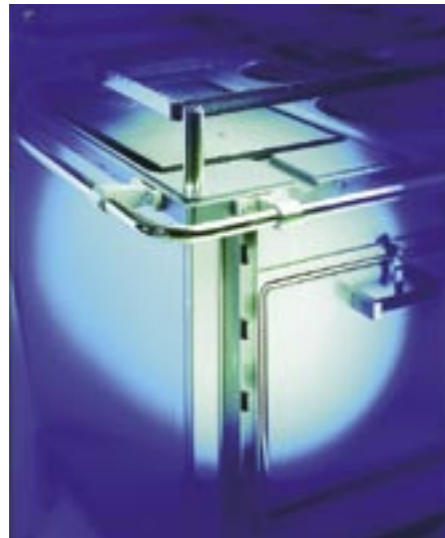

BEHA-HEDO INDUSTRIER AS
 PO Box 2704 Kjorbekk • NO-3702 Skien, Norway
 Tel: +47 35 93 20 00 • Fax: +47 35 93 20 01
 E-mail: beha-hedo@beha-hedo.com
 Website: www.beha-hedo.com

Beha-Hedo Industrier AS has more than 80 years of experience in the galley and laundry business since it was established in 1917. The company supplies the cruise industry, the merchant fleet, fishing boats and shipyards worldwide. Both new ships and refitting assignments are a part of its core business. The company supplies turnkey solutions as well as bits and pieces. Beha-Hedo's philosophy is to supply functional, heavy-duty equipment that is tailored to cope with a rough sea environment for shipboard galleys and laundries. The company's products are known for their good quality, reliability and durability.

Layout & Planning

A well-planned kitchen or galley increases efficiency and makes working pleasurable. Beha-Hedo makes great demands on ergonomics, atmosphere, economy and operation when designing a workplace. Using CAD/CAM equipment and special programmes, the company can provide customers with 3D drawings in colour that give the optimal impression of how the kitchen or galley will look, with the option of seeing it from different angles if so desired.

Turnkey Solutions

Beha-Hedo takes care of the layout planning and engineering work. It supplies the equipment required according to customer specifications for a complete galley, pantry and laundry. In addition to what the company manufactures it can offer a total package which includes supplementary products from highly reputed domestic and international subcontractors.

In-House Production

Beha-Hedo's long experience in its in-house productions has given the company valuable know-how for determining the appropriate quality for its galley and laundry equipment. Its factory is highly flexible and the company is accustomed to placing its customers at the centre of attention.

Beha-Hedo specializes in making appliances for cooking, frying and keeping food warm. Its sectional galley ranges are well known all over the world. The company has supplied thousands of units over the years for all kinds of ships.

Beha-Hedo's products include:

- Ranges
- Cooking tables
- Hotplates
- Hot counters
- Bain-marie
- Banquette cupboards
- Warm plate
- Frying pans
- Baking/roasting ovens

- Refrigerators
- Freezers
- Cold counters
- Food slicers

After-Sales Service

Beha-Hedo stocks the most frequently needed parts for all of its equipment and ships within hours of receiving an order by the swiftest means of transportation.

The company has also built up a network of international distributors and agents who can assist customers whenever it is required.



BJØRGE STEINCO MOLAND
 Arendal:
 Teknologiveien, Longum Agderparken
 Servicebox 712 • NO-4808 Arendal, Norway
 Tel: +47 37 05 97 00 • Fax: +47 37 05 97 10

Bømlo:
 Hollundsdalen • NO-5430 Bremnes, Norway
 Tel: +47 53 42 88 00 • Fax: +47 53 42 88 01

E-mail: bsm@bjorge.no • Website: www.bjorge.no

Bjørge Steinc Moland is an international supplier of advanced automation systems to ships and offshore installations, such as integrated automation systems, ship stabilizers, remote control systems, cargo control systems, power management systems, data loggers and more. Bjørge Steinc Moland was formally established in 1978, but its history goes back to 1966. Today the company is a central part of the Norwegian marine and offshore industry and a part of Norwegian concern Bjørge ASA.

Marine

Bjørge Steinc Moland supplies a range of products to ships of all sizes. These products include:

- Integrated automation systems
- Ship stabilizers
- Remote control systems
- Cargo control systems
- Power management systems
- Data loggers

The company has a great deal of experience in supplying "packages" that take care of system integration, in addition to delivering systems such as main electrical switchboards, CCTV and fire alarm systems. This gives more optimal solutions with lesser points of contact.

Bjørge Steinc Moland has established relations and cooperation with leading and reliable system providers covering several ship automation functions.

Offshore

As a part of the world's most advanced offshore industry, Bjørge Steinc Moland provides solutions for safety, monitoring and control systems for cranes and anchor winches, control systems for thruster plants and data loggers. In addition, an advanced protection system used to monitor heating current on deep-sea pipelines that transport crude oil is also provided.



SMARTchief II

Integrated Automation System (IAS)

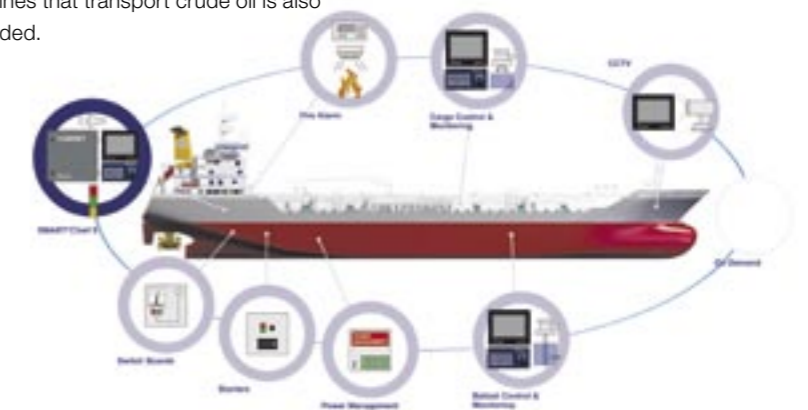

www.bjorge.no



Member of the Koppernæs Group



SAFETY SOLUTIONS

BRUDE SAFETY AS
 PO Box 4 Breivika • NO-6025 Aalesund, Norway
 Tel: +47 70 17 77 00 • Fax: +47 70 17 77 01
 E-mail: office@brude.no • Website: www.brude.no

Brude Safety AS is a part of the Koppernæs Group, which operates in three main sectors: marine safety equipment, fish processing, and supply chain management (fasteners and tools). The group sales for 2004 totalled €80 million. The Koppernæs Group employs 300 people on three continents.

Complete Solutions for Safety at Sea

Brude Safety AS provides complete equipment packages from quality producers. The company also offers owners after-market services for its products along the entire Norwegian coast and through its partners worldwide. Brude Safety AS, through its offshore and onshore presence, has provided services for a number of major projects and supplied products to major oil platforms, including Gullfaks B, Draugen, Heidrun, Troll A, B and C, Åsgard A and B, Njord, Siri, Jotun A and B, Ekofisk II, Eldfisk, Visund, Oseberg East, Snorre B, Tambar, Huldra, Valhall, Grane, Kvitebjørn, Kristin, AGIP KCO, Ekofisk 2/4M, and the Sakalin II Phase 2 CGS project. The company has also provided services for onshore plants, including the Troll onshore plant, Tjeldbergodden methanol plant and Ormen Lange.

Fire-Fighting Equipment

Koppernæs Brude Safety AS offers a complete range of fire-fighting equipment, enabling the shipyard and owner to rely on a single supply source. Such installations are tailor-made for each vessel. The company also supplies fire-fighting equipment, smoke-diving equipment and other safety products needed to outfit ships and installations.

Marine Evacuation Systems (MES)

Brude Safety AS offers a variety of MES mainly aimed at passenger vessels. The KOPAS system, used aboard catamarans and passenger ferries, consists of a telescopic aluminium gangway with a built-in raft. The system is released from the bridge, is fully automated and needs no crew members for operation. KOPAS is suitable for evacuation heights of up to four metres.

The newly developed BRUDE MES 300 chute system consists of one chute and one container carrying two rafts for 150 persons. The system is suitable for evacuation heights of up to 15 metres. Brude Safety also offers slide systems. This solution is often used on catamarans, and is also EU type-approved by See Berufs Genossenschaft (SBG). The company also runs an extensive system of replacement rafts so that the ship can continue operations uninterrupted.

All systems are tested in accordance with the IMO resolution MSC81 (70) under the supervision of SBG as the notifying body, and consequently all systems are EC type-approved (Wheelmark). Brude Safety has also obtained USCG approval.

Safety & Rescue Equipment

Supplying ship and offshore installations with safety equipment implies meeting stringent requirements. Brude Safety AS has for many years proved itself capable of meeting these demands for safety and rescue equipment. Products here include:

- Life rafts
- MOB/FRB boats
- Davits/cranes
- Survival suits
- Life jackets
- Lifebuoys
- Pyrotechnic equipment
- Medical equipment

Nautical, Signalling & Mooring Equipment

Brude Safety AS has a wide selection of nautical and signalling equipment, enabling it to supply for all relevant needs. The product line includes:

- Compasses
- Signalling and sounding equipment
- Ropes
- Chart instruments
- Chronometers, clocks and barometers
- Flags
- Publications
- Mooring ropes



BRUNVOLL

BRUNVOLL AS • 6415 MOLDE • NORWAY

BRUNVOLL AS
 Strandgata 4-6 • NO-6415 Molde, Norway
 Tel: +47 71 21 96 00 • Fax: +47 71 21 96 90
 E-mail: office@brunvoll.no • Website: www.brunvoll.no

Brunvoll AS has more than 90 years of experience in marine propulsion and is one of the world's leading manufacturers of thruster systems. The company has delivered and installed over 6,000 thrusters worldwide to fishing vessels, cruise ships, tugs, offshore support ships and vessels for dynamic positioning.

Bow & Stern Thrusters

Brunvoll Tunnel Thrusters are available with controllable or fixed-pitch propellers. The company offers noise suppression technology for tunnel thrusters which results in noise reductions of 12-15dB(A).

Azimuth Thrusters – Retractable/Non-Retractable

Brunvoll Azimuth Thrusters provide main or auxiliary, inboard or outboard propulsion and manoeuvring with 360° turn, using controllable or fixed-pitch propellers.

Thruster Drive & Control Systems

The company offers complete thruster drive and control systems individually tailored to each vessel. As a total

thruster system supplier, Brunvoll has full knowledge of all components in the installation. Thus, service and support can be obtained from a single responsible supplier.

Sales & Service Network

Brunvoll has a worldwide network of sales and service stations with multi-disciplinary service personnel available on a 24/7 basis. The company has a well-stocked warehouse of spare parts, which are available for shipment on short notice.

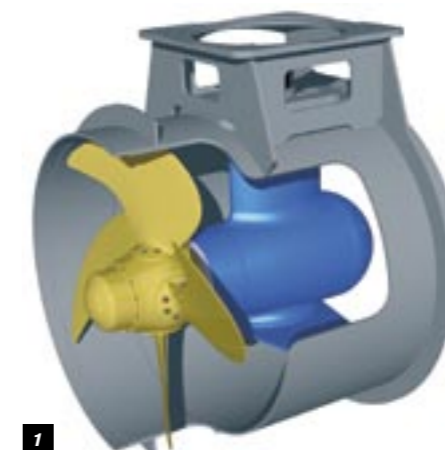

1. Brunvoll tunnel thruster.



2. Brunvoll Combined Retractable Azimuth and Tunnel Thruster.



MANAGING RISK



DET NORSKE VERITAS
 NO-1322 Høvik, Norway
 Tel: +47 67 57 99 00
 Website: www.dnv.com

Established in 1864, Det Norske Veritas (DNV) has the objective of safeguarding life, property, and the environment. The company's core competence is to identify, assess, and advise on how to manage risk.

DNV Overview

Managing risk is at the core of everything DNV does, all over the world. Whether it classifies a ship, certifies an automotive company's management system, or advises on how best to take care of an aging oil platform, managing risk is the company's main focus and priority. DNV is an independent, autonomous foundation. This means that it can balance the needs of business and society, based on its independence and integrity.

DNV is an international company with 300 offices in 100 different countries. Headquartered in Oslo, Norway, DNV's global network is linked together by state-of-the-art information technology that enables it to create value for its customers in a consistent manner worldwide. The company's prime assets are the creativity, knowledge and expertise of its 6,400 employees from more than 80 different nations, most of them highly qualified.

DNV operates in multiple industries internationally, and is organized into four business areas – DNV Maritime, DNV Technology Services, DNV Certification and DNV Consulting.

DNV Maritime

DNV Maritime is a world-leading classification society, helping the maritime industry to manage risk in all phases of a ship's life, through ship classification, statutory certification, fuel testing, and a range of technical, business risk and other competence-based services. DNV Maritime develops rules and establishes requirements for ships, and its surveyors ensure that these requirements are met.

Developing Future Services

DNV invests in research to develop future services that will safeguard life, property and the environment. Through exploring new technologies and building knowledge, the company's customers are provided with the best possible value over a long-term perspective. Wherever the company is, and whatever it does – 6,400 DNV colleagues take pride in working for a knowledge-based organization with a broad range and depth of competence.



DUALOG AS
 Alkeveien 14 • NO-9015 Tromsø, Norway
 Tel: +47 77 62 19 00 • Fax: +47 77 62 19 01
 E-mail: sales@dualog.com • Website: www.dualog.com

Established in 1994, Dualog AS is one of the world's leading maritime data communications providers. The company develops and markets a complete software solution for communication between ship and shore. Dualog now has its eyes set on the future.

Today, shipping companies need to stay in touch with their fleet in order to stay ahead. Some of the reasons for this include necessary reporting within companies and to authorities, crew welfare, and the complex information and communication needs in order to run operations smoothly.

Internet Shapes the Future of Ship-Shore Communications

E-mail, websites, chat, blogs, online encyclopedias, user forums, 24-hour banking, online reporting, online bookstores and more have already changed the way people interact, the way people look up information – and the way the world does business.

For the maritime industry the question is not if one should consider these changes, but how to turn new technology into competitive advantages.

Maritime Communications Expert

Dualog has been one of the leaders in the maritime data communications industry since the days of VHF and early Inmarsat communications. It has built its reputation on the proud heritage of Norwegian shipping and technological advances and insights.

Products & Options

Today, Dualog systems are installed on more than 600 ships, from fishing vessels to large bulk carriers. The company's main products include:

- **Dualog Communicator®**
 – An e-mail and file transfer software solution that connects ships to shore via satellites and mobile communications in a safe and cost-effective manner.
- **Dualog Operator®**
 – A sophisticated web-based software that provides real-time access to traffic information, statistics, configuration and billing data.

Dualog systems support all of the commonly used communication systems, including all Inmarsat systems, Iridium, GSM (GPRS, EDGE, UMTS) and VSAT. Future releases of Dualog systems will also include advance support for new communications systems like Wimax. WLAN protocols 802.11a-g and other IP-based communications systems.

The systems allow users to choose which e-mail client they will use. Also, they support most onboard applications, and e-mail addresses and domains can be freely formatted as preferred. There is also an option to run Microsoft Exchange or Lotus Domino servers aboard the vessel.

Dualog provides 24-hour support to an increasing and demanding clientele of shipping companies worldwide.

Speeding Up the Pace of Innovation

The company has set ambitious goals for the future. In the coming years Dualog will put knowledge and expertise to the test in the making of a new-generation communication and information software solution for the maritime industry.

Offices

Dualog is based in Tromsø, Norway, has an office in Oslo that serves Europe, and one in Singapore for the Asian markets. The company has 30 employees and service partners in Germany, Great Britain, the Netherlands and the United Arab Emirates.

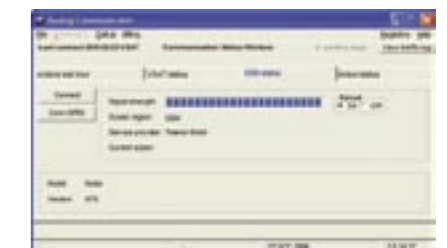



EKSPORTFINANS

EKSPORTFINANS ASA
 PO Box 1601 Vika • NO-0119 Oslo, Norway
 Tel: +47 22 01 22 01 • Fax: +47 22 01 22 02
 Website: www.eksportfinans.no

Eksportfinans ASA – the Norwegian export credit agency – provides financing for export of Norwegian capital goods and services. Financing of deliveries to the global maritime sector is one of its major areas of activity. Eksportfinans structures competitive financial packages to meet the specific needs of individual clients and projects.

Financing the Maritime Sector

Eksportfinans offers competitive medium and long-term financing for the export of:

- Ship's gear
- Shipyard equipment
- Services
- Ships

Eksportfinans recently provided financing for all of the Norwegian ship's gear and services to the vessel *Boa Sub C* contracted by the Norwegian shipowner Boa AS (*Taubåtkompaniet*). Eksportfinans has also financed Norwegian deliveries to several projects for shipowners in Turkey and several offshore service vessels built at Norwegian shipyards.

If the Norwegian ship's gear package constitutes a significant part of the value of the ship, attractive financing terms in line with OECD ship financing conditions

will apply. These include financing of 80 percent of the contract, and loan periods of up to 12 years. Eksportfinans recently received acceptance for financing offers covering substantial equipment packages – including shipowners building ships in Croatia, China and Russia.

Advantages

When the buyer evaluates offers from various foreign suppliers, the financial solution may be crucial. A financial offer from Eksportfinans for tailor-made medium or long-term financing is free of charge and without obligations for the Norwegian exporter and the foreign client. Financing through Eksportfinans ensures:

- Cost-effective solutions
- Predictability
- Flexibility – fixed or floating interest rates and loan structures at the borrower's request
- Interest cap – free of charge
- Long-term financing
- All convertible currencies
- The seller receives payment according to contract terms

How to Proceed

Please contact Eksportfinans at the above address and telephone number, or have the Norwegian supplier approach Eksportfinans for a financial offer. To ensure an efficient consideration of the project in question, Eksportfinans requires a written application including the following information:

- Loan applicant
- Supplier
- Borrower/buyer
- Project description
- Contract amount and preferred financing
- Collateral

Further information and an electronic application form are available at

www.eksportfinans.no

Havila Shipping's *Havila Star*, one of many offshore vessels financed by Eksportfinans ASA.



ENWA AS
 PO Box 257 Forus • NO-4066 Stavanger, Norway
 Tel: +47 51 63 43 00 • Fax: +47 51 63 43 01
 E-mail: post@enwa.com • Website: www.enwa.com

ENWA manufactures chemical-free water treatment products and systems, specializing in filtration and membrane technology. This technology has proven to be environmentally friendly and superior in terms of energy efficiency and cost-effectiveness.

Reverse Osmosis (RO) Fresh Water Maker

ENWA develops and manufactures desalination units based on Reverse Osmosis (RO). It is used on ships, yachts, offshore vessels, drilling rigs and platforms throughout the world. RO units from ENWA are also used in numerous onshore industrial applications, such as food treatment plants, refineries and terminals. The units are cost-effective and known for their reliability and user-friendliness.

The supply of fresh water is an important issue in marine environments. ENWA's products employing the RO process will, in most circumstances, be the most efficient, economical and environmentally friendly ways of safeguarding the water supply. Using ENWA's proven RO technology eliminates the

potential danger of contamination coming from bunker water. In addition, the RO Fresh Water Maker also significantly reduces the possibility of bacteriological contaminations such as, for example, Legionella and E.coli.

Green Ship Technology

EnwaMatic® Chemical-Free Water

Conditioner replaces chemical dosing in:

- Comfort cooling and heating systems (HVAC)
- Engine cooling systems

In any freshwater-based, closed loop, cooling or heating system, water quality is most important for protecting against corrosion and operation according to design. Corrosion, scaling and bacterial growth reduces overall capacity. Treated water protects against operational problems and high maintenance costs.

Traditionally this water treatment has been carried out using chemical injections. This is a rather expensive treatment method – as chemical and waste handling related to this method has to operate according to regulations. ENWA's DNV-approved (Report # 270113) MWT by EnwaMatic® technology provides a safe, chemical-free and environmentally friendly solution that also saves money.



1. Maritime water treatment by EnwaMatic®. Patented worldwide.

ENWA BIN-X® Chemical-Free Bacteriological Barrier for Drinking Water

In drinking water systems, there are conditions that can represent a threat to the quality of the water. These can harm a person's health and even be life-threatening if outbreaks of Legionella and E.coli-related epidemics develop.

ENWA's BIN-X® is a patented, cost-effective, water treatment system used for the removal of particles and bacteria such as Legionella and E.coli from potable water/drinking water, offering maximum security against related epidemics.

Traditionally, UV systems and chemical treatment are used to neutralize bacteria in potable water systems. The ENWA BIN-X® employs ultra-filtration to remove bacteria and the membranes are self-maintained by an automatic patented back wash/flush technique. Consequently, time spent on system maintenance is very limited.

The ENWA BIN-X® has VA (water and discharge) approval for installation in drinking water. It operates in high temperatures so that both cold and hot water systems can be treated and protected.



FJERBY AS
 PO Box 53 • NO-2025 Fjerdingsby, Norway
 Tel: +47 64 80 26 50 • Fax: +47 64 80 26 55
 E-mail: firmapost@fjerby.no
 Website: www.fjerby.no

Founded in 1979, Fjerby AS is a leading supplier of safety and anti-skid coatings for the marine industry. Currently the company's main export markets are Europe, the Far East and the United States.

Anti-Skid Expertise

Over the years, anti-skid protection on Ro-Ro ramps has been synonymous with steel bars welded horizontally or in a fishbone pattern, stretched metal, or fine sand in deck paint. These have different advantages and disadvantages: the fishbone pattern generates more noise than traction; stretched metal offers reasonably good traction, but is extremely difficult to keep clean and is expensive to maintain; and while sand in deck paint is inexpensive, it only remains effective for a brief period of time.

Fjerby has developed a high-quality alternative to traditional anti-skid protection. The company's Safegrip® coatings combine low weight with high durability, providing a non-skid surface for steel, concrete and wood. Safegrip® is ideal for Ro-Ro and ferry ramps, ship decks and other wet or dry shipboard surfaces. With a spark-free design and low flame dispersion, it is particularly well-suited for use on drilling platforms and ferry decks.

Customer Service

Fjerby offers a high level of expertise, service and systems tailor-made to meet with client specifications.

International References

- Fjerby's references include:
- DFDS Tor Line
 - The harbours of Stockholm, Gothenburg, Oslo, Varberg and Kapellskär
 - Irish Ferries
 - MacGregor Oslo, Bergen, Gothenburg and Turku
 - The Norwegian Coastal Administration

- Norent
- Norske Shell
- Scandlines DSB
- J. J. Sietas KG Shipyard
- TTS Ships Equipment
- Wallenius Lines
- Norfolk Line
- Barber Marine Consultants
- Eukor



Frank Mohn AS

FRANK MOHN AS
 PO Box 98 Slåtthaug • NO-5851 Bergen, Norway
 Tel: +47 55 99 90 00 • Fax: +47 55 99 93 80
 E-mail: marine@framo.no • Website: www.framo.no

Frank Mohn AS, located outside of Bergen in western Norway, is the leading supplier of submerged cargo pumps to the world tanker market. More than 31,700 Framo submerged cargo pumps are in service onboard some 2,110 tankers. In 2005 alone 189 complete cargo pumping systems were commissioned.

Innovative Design

Frank Mohn AS pioneered the development of hydraulically driven submerged cargo pumps. The innovative design has changed the way tankers are built and operated today.

The company's cargo pumps are supplied in a wide range of capacities from 50m³/h to 2,000 m³/h, with total discharge rates up to 15,000 m³/h. Framo Cargo Pumping systems are installed onboard chemical carriers, product tankers, large crude and OBO carriers and FSO/FPSO units.

A Total Concept

A Framo Cargo Pumping System comprises:

- Cargo pumps
- Ballast pumps
- Bow thruster motor
- Deck-mounted cargo heaters
- Hydraulic piping system
- Control system

Worldwide Service

The Framo Cargo Pumping system includes professional assistance during project evaluation, technical support during engineering and supervision of installation and testing. The company's worldwide service organization takes care of spare parts, technical services and training.

Additional Products

The Frank Mohn range of products also includes:

- Portable pumping systems
- Oil recovery equipment
- Anti-heeling systems
- Offshore pumping systems
- Worldwide pump rental services

All FRAMO products are manufactured in Norway.

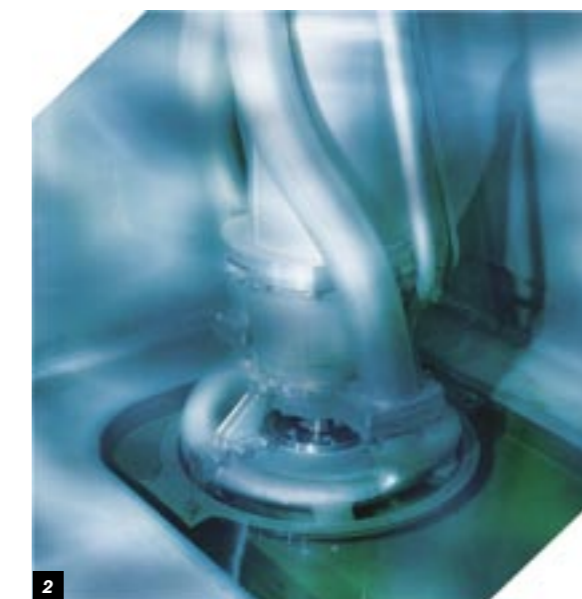

1. Locations worldwide.

2. Framo submerged cargo pump.



www.hamworthy.com

HAMWORTHY GAS SYSTEMS AS
PO Box 144 • NO-1371 Asker, Norway
Tel: + 47 81 54 85 00

HAMWORTHY PUMP SYSTEMS AS
PO Box 53 • NO-1371 Asker, Norway
Tel: + 47 81 54 86 00

HAMWORTHY MOSS AS
PO Box 1053 • NO-1511 Moss, Norway
Tel: + 47 69 27 99 00

Hamworthy plc has headquarters in Poole, UK, and three companies in Norway. Hamworthy designs and manufactures a wide array of products and systems for the global shipping and offshore market, and the company's well-qualified service personnel provide around-the-clock support and service worldwide.

Hamworthy Gas Systems AS

E-mail: gasinfo@hamworthy.com

The company specializes in engineering and the turnkey supply of complete LPG

and LNG cargo handling systems for gas carriers, F(P)SOs and FSRUs. Products like LPG and LNG reliquefaction plants, LNG regasification plants, gas cooling plants and heat exchangers are of own

design. Hamworthy Gas Systems AS also delivers VOC recovery systems for crude oil shuttle tankers and small LNG liquefaction plants for land installation.

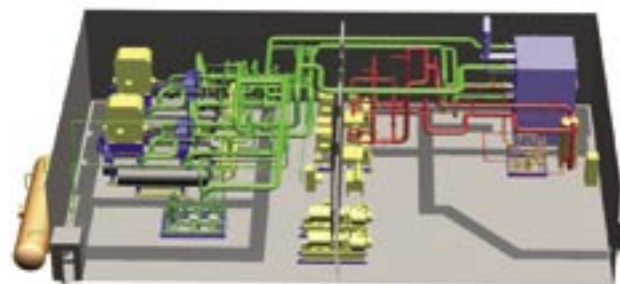

1



2



3

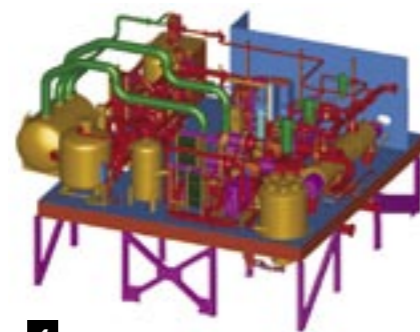

4

- 1. LNG reliquefaction plant.
- 2. LPG reliquefaction plant.
- 3. LPG cooling plant.
- 4. VOC recovery plant.

Hamworthy Pump Systems AS

E-mail: pumpinfo@hamworthy.com

The company specializes in the engineering and package supply of cargo

and ballast pumping systems for offshore applications of electric deepwell and conventional pump room type, fire pump

systems, seawater lift pumps and general engine room pumps. All pumps are of centrifugal type.



5



6

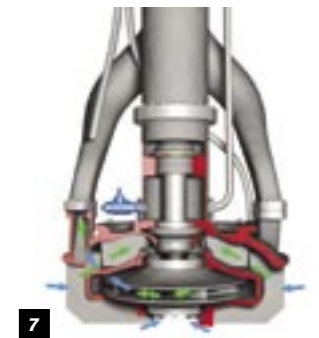

7



8

- 5. Pump room cargo pump – CB.
- 6. Engine room pumps – C2G.
- 7. Deepwell pump – CLK.
- 8. Fire pump skid to NFPA 20.

Hamworthy Moss AS

E-mail: moss@hamworthy.com

The company specializes in the development, design and service of inert gas and nitrogen generator systems for use onboard ships and offshore installations. The systems share several

fundamental characteristics – high efficiency, ease of installation, use and maintenance, and worldwide serviceability. More than 1,500 Moss inert gas systems are in operation.



9



10



11



12

- 9. IGS skid interface.
- 10. IGS dual fuel generator.
- 11. IGS skid in hazardous area location.
- 12. IGS skid in safe area location.



HELSETH AS
 Bakliveien 11-13 • NO-6450 Hjelset, Norway
 Tel: +47 71 20 29 00 • Fax: +47 71 20 29 01
 E-mail: helseth@helseth.no • Website: www.helseth.no

Helseth AS has delivered propeller systems to the shipping industry for 90 years. Today, the company manufactures controllable-pitch propeller (CPP) systems in the 100–3,000 kW power range. Helseth propeller systems – all tested under the harsh conditions of Norway’s coastal waters – have been fitted on more than 7,500 vessels.

CPP for Work & Fishing Boats

Helseth’s 3- and 4-blade controllable-pitch propeller systems combine a reduction gearbox with built-in hydraulic servo unit or shaftline servomotor. Propellers are available in the following range of diameters:

- 3-blade propellers: 700–2,200 mm
- 4-blade propellers: 1,400–4,100 mm

CPP for Fast-Running Vessels

Helseth designs its propellers using state-of-the-art computer analysis for maximum efficiency on vessels with speeds up to 35 knots. Propellers are available for the 300–2,500 kW range.



HERNIS SCAN SYSTEMS AS
 PO Box 619 • NO-4809 Arendal, Norway
 Tel: +47 37 06 37 00 • Fax: +47 37 06 37 06
 E-mail: cctv@hernis.no • Website: www.hernis.com

HERNIS SCAN SYSTEMS – Asia Pte Ltd
 6 Changi North Street 1 • 2nd Level, Spanners Building
 Singapore 498825
 Tel: +65 6545 9068 • Fax: +65 6542 9068
 E-mail: cctv.singapore@hernis.com

HERNIS SCAN SYSTEMS – US Inc.
 Dairy Ashford Plaza • Suite #495, 2000 Dairy Ashford
 Houston, TX 77077 USA
 Tel: +1 281 560 8050 • Fax: +1 281 560 8054
 E-mail: cctv.houston@hernis.com

HERNIS Scan Systems AS is a world leader within high-quality closed-circuit television systems (CCTV) and visual integrated systems (V.I.S.), which is a visual concept based on integration into various onboard computer-based systems. The systems are tailor-made for hazardous and corrosive environments, as well as for the luxurious environments found onboard cruise ships.

CCTV & V.I.S.

The CCTV systems are self-contained systems made to suit the needs of projects of all sizes. V.I.S. is a virtually unlimited system, tailor-made to fulfil special demands occurring in projects such as the highly demanding cruise market, and complex oil and gas projects.

HERNIS can offer a comprehensive CCTV/V.I.S. package, covering assessment of the client’s needs, initial design, engineering, manufacturing, installation, testing and supply of detailed documentation to customer specifications. HERNIS’ employees have extensive experience in project development. They are uniquely qualified to provide advice on CCTV/V.I.S. systems to engineering companies and operators within the maritime and oil and gas industries.

1. In close cooperation with Royal Arctic Line AS in Denmark HERNIS completed a successful pilot project onboard the M/S *Mary Arctica* in the spring of 2006, putting two HERNIS thermal camera stations to the test for the challenging task of ice detection under the extreme conditions in the waters around Greenland.

CCTV Technology

The use of CCTV allows for centralized monitoring from one control station, providing complete overview of all areas and processes on ships, oil rigs, production plants and refineries. A person monitoring all critical areas from a central control point can respond to a series of simultaneous events more efficiently than a number of individuals located in the field, improving safety and ensuring increased productivity.

Protecting Sensitive Equipment

To withstand harsh environments, from the heat and humidity of the Middle East to the arctic frost of the North Sea, HERNIS has developed housings and enclosures made of maintenance-free, electro-polished stainless steel. This material has been chosen to give maximum protection to the sensitive equipment within the unit.





J. MARTENS AS
 PO Box 567 Sentrum • NO-5806 Bergen, Norway
 Tel: +47 55 21 08 00 • Fax: +47 55 21 08 08
 E-mail: jm.bergen@jmartens.com
 Website: www.jmartens.com

J. MARTENS (ASIA PACIFIC) PTE LTD SINGAPORE
 137 Telok Ayer St., # 05-07 • Singapore 068602
 Tel: +65 6416 3036 • Fax: +65 6536 7972
 E-mail: martin@jmartens.com.sg

J. Martens AS has provided transport solutions since 1880, and is renowned for reliability. From its head office in Bergen, J. Martens AS draws on in-house expertise and a worldwide network of dependable partners to provide the shipping and offshore industries with a wide range of transport and logistics services.

Vast Array of Services

From complex pre-shipment planning – including packing, stowage and securing of oversized cargos – to seamless terminal operations and more, J. Martens AS offers a full range of services comprising:

- Project forwarding worldwide
- Chartering worldwide
- Liner agencies and freight forwarding
- Agency and clearance
- Heavy lifting
- Airfreight
- International and domestic trucking
- Customs clearance and documentation

Offices Throughout Norway

In addition to its head office in Bergen, J. Martens AS has offices in Sandnes/ Stavanger, Haugesund, Mongstad, Ålesund and Kristiansund.



JETS VACUUM AS

JETS VACUUM AS
 PO Box 14 • NO-6069 Hareid, Norway
 Tel: +47 70 03 91 00 • Fax: +47 70 03 91 01
 E-mail: post@jets.no • Website: www.jets.no

Jets Vacuum AS is a leading manufacturer of vacuum sanitary systems. The company's headquarters are located on the western coast of Norway and it has a worldwide network of highly qualified professionals.

Sanitary Systems – Made to Please

Jets Vacuum AS was born from a brave commitment to a good idea. The company had a strict upbringing in the maritime community of western Norway, which is renowned for innovative quality products with robust performance.

Every Second Newbuild Chooses Jets

Today the company has evolved into an international enterprise whose solutions are chosen for every second newbuilding that has vacuum sanitation. The compact in-line Jets system is based upon decades of experience in finding out what works best and most efficiently in practice – and at the lowest cost.

Acceleration of Installations

Since 1987 the yearly rate at which Jets sanitary systems are installed is accelerating. They have now been installed on over 4,500 ships.

Optimal Jets System for Any Ship

With its unique design flexibility, Jets sanitary systems are suitable for a wide range of marine applications. Simple in-line installation, no need for tanks, small footprint and scope for tailor-made configurations make Jets the preferred solution for vessels from fishing boats to cruise ships.

Jets Vacuumator

The patented Jets Vacuumator is one of the most compact, efficient and reliable vacuum generators available for vacuum toilet systems. Some of its features include:

- A proven record of low maintenance, with a transparent cover to make inspection easy
- Monobloc design with motor, screw and macerator on the same shaft
- Safe and simple construction with few moving parts
- No need for external supply of liquid





JOTRON AS
 PO Box 54 • NO-3280 Tjodalyng, Norway
 Tel: +47 33 13 97 00 • Fax: +47 33 12 67 80
 E-mail: sales@jotron.com • Website: www.jotron.com

Jotron AS was established in 1967 and has 40 years of experience in the design and manufacture of radio communications equipment. The factory exports its products worldwide and is certified according to NS-EN ISO 9001:2000.

Maritime Products

Jotron is a major supplier of GMDSS-specified emergency radio equipment that fulfils IMO requirements. Its GMDSS product line includes emergency radio beacons, portable VHF transceivers and radar transponders. All are mandatory for commercial vessels, fishing vessels and large pleasure craft. Jotron also manufactures high-intensity xenon and infrared markers, along with emergency lights.

Jotron now offers a new float-free capsule for VDR and S-VDR systems. The Tron S-VDR Capsule combines the best EPIRB features with voyage data storage media in a float-free capsule. The capsule is applicable for SOLAS ships from 2006.

AIS Transceiver

The Tron UAIS TR-2500 is a VHF transponder system continuously exchanging own ship information with information from all UAIS-equipped ships within VHF range. The AIS Transceiver is fully compliant with all IMO-relevant product standards.

The Jotron Group

Jotron AS has ownership in a number of technology companies that support the organization with technology, marketing know-how and products. One of these companies is Jotron Phontech AS, located in Horten, Norway.

Jotron Phontech AS

Jotron Phontech AS develops and markets intercom systems, batteryless telephone systems and integrated communications systems. Based on the latest technology, Jotron Phontech's new generation products are developed to meet international standards for all types

of onboard communications systems. The company sells its products through authorized agents worldwide.

Additional Products

Jotron's wide range of VHF and UHF ground-to-air radio equipment for voice communications at airports and offshore applications meets current aviation standards.

1. The TR-710 VHF-AM desktop transceiver and TR-7510 VHF-AM transceiver.
2. The Tron UAIS TR-2500 universal automatic identification system.
3. Jotron's new Tron S-VDR Capsule.
4. The Tron TR20 hand portable transceiver.
5. The Tron SART radar transponder.
6. The Tron 40S EPIRB is also available with integrated GPS.



KONGSBERG

KONGSBERG MARITIME AS
 Kirkegårdsveien 45 • PO Box 483
 NO-3601 Kongsberg, Norway
 Tel: +47 32 28 50 00 • Fax: +47 32 28 50 10
 E-mail: km.sales@kongsberg.com
 Website: www.kongsberg.com

With 2,500 employees in Canada, China, Germany, Italy, Korea, the Netherlands, Singapore, Sweden, the United Kingdom, the United States and six locations in Norway, Kongsberg Maritime is the world's largest manufacturer of marine electronics.

Leading Technologies

Kongsberg Maritime builds leading technologies within:

- Dynamic positioning, joystick and thruster control systems
- Radar, ECDIS, autopilot and navigation systems
- Voyage data recorders and AIS
- Integrated automation systems
- Propulsion control systems
- Cargo handling systems
- Sensors and transmitters

- Process control and safety systems
- Altimeters, echo sounders, sonars and underwater cameras
- Underwater vehicles and instrumentation
- Acoustic BOP control system
- Acoustic positioning, HPR and HIPAP
- Telemetry link and transponders
- Attitude determination systems
- Simulator systems
- Fish-finding equipment

Kongsberg Maritime maximizes marine performance.





L-3 VALMARINE AS
 PO Box 881 • NO-3007 Drammen, Norway
 Tel: +47 32 21 81 00 • Fax: +47 32 82 20 77
 E-mail: valmarine@l-3com.com
 Website: www.mapps.l-3com.com

L-3 Valmarine is a major supplier of automation and navigation systems to advanced vessels worldwide. The cruise vessel market is its core business and the company is the market leader in ship automation in this segment. In general, the systems are designed with a high degree of automation and safety, enabling the company's products to be present on both LNG and offshore vessels. The company employs 100 people and is headquartered in Norway, with a branch office in Finland and cooperation partners in Italy, France, Singapore, PRC and South Korea. L-3 Communications, with headquarters in the US, is the principal owner and L-3 Valmarine is a part of the Power and Control System Group.

Products

L-3 Valmarine was established in 1979 and was the first supplier in the merchant marine market for Integrated Automation Systems (IAS). The product name is Damatic™, which is synonymous with reliability, safety and a high level of integration. The current version of the Damatic™ system, DNA, offers an advanced HMI solution for operators and maintenance personnel. The system concept is modular and flexible with high processing power to solve the most demanding functional tasks. The built-in redundancy features guarantee undisturbed ship operation, which is a vital feature in today's demanding ship operations.

For navigation, L-3 Valmarine offers an integrated bridge system (IBS), which is designed according to today's demanding requirements within the naval and commercial marine sectors for functional flexibility and operability. The main IBS functions are radar, ECDIS, track steering and VDR, which are all accessible from any multifunctional workstation. The system is very adaptable to special functionalities required for Navy ships' IBS.

Product Areas

- L-3 Valmarine's product areas are:
- Machinery control and monitoring
 - Propulsion control
 - Power management
 - HVAC automation
 - Bilge control
 - Ballast control
 - Cargo control
 - Emergency shutdown control
 - Safety management
 - Information management
 - Asset management
 - Integrated bridge systems

Service

L-3 Valmarine's Customer Support office is in Drammen, Norway and is a 24-hour on-call support facility. Service attendance

for North America is supported from a dedicated L-3 Valmarine service station in Miami, US.

Training

L-3 Valmarine Customer Training Centre has professional training facilities, including simulators and computer-based training. A team of professional instructors, with long experience in the field of marine automation, offers a wide range of training programmes.

Parent Company

The parent company, L-3 Communications, was established in 1997, employs 60,000 people worldwide and has a group turnover of \$12 billion. L-3 Communications is listed on the New York Stock Exchange.



LILAAS AS
 PO Box 705 • NO-3196 Horten, Norway
 Tel: +47 33 03 18 50 • Fax: +47 33 03 18 60
 E-mail: lilaas@lilaas.no • Website: www.lilaas.no

Lilaas AS was established in Horten in 1961, and has more than 40 years of experience in the manufacturing of mechanical products for offshore and onshore applications. Offering a complete range of control levers and joysticks for the maritime market, the company markets its products worldwide. The products are certified by DNV, and the company is certified under NS-EN ISO 900:2000. Lilaas has many well-known corporations on its client reference list.

Product Range

Lilaas AS is a well-known supplier and Norway's largest manufacturer of various types of control levers and joysticks. Unique but simple designs, top-grade materials and thoroughly tested products ensure safe control and require little service or maintenance. The products range from simple, one-axis control levers in different sizes, hand wheels, rudder controls and azimuth controls to multi-axis joysticks.

All products are available as motorized units on all axes and offer a number of other optional features. The levers are tested and certified by DNV, and have passed tests based on "worst-case" methods with excellent results. Accordingly, they meet the requirements posed by certification offices. All types of maritime vessels – ranging from fishing boats, ferries and supply vessels to

tankers and cruise ships – can be controlled by Lilaas control levers.

AESS – Electronic Shaft System

Lilaas' new Electronic Shaft System, AESS, is available on all control levers, offering a CANopen bus-based system that complies with the new maritime standard regulations. Using an interface, the highly redundant system can be integrated into the main control system of a ship. AESS can then set all of the vessel's levers to the same position to facilitate easier takeover. The system features high reliability, low-cost installation and is simultaneously compact, flexible and ready for future expansion.

Industrial Applications

The company makes small, precise, fine mechanical parts for industrial applications as well. Using state-of-the-art CNC-

controlled machine tools, the factory also manufactures small-tolerance products for medical, space-related, underwater and electronic applications in general.

Design

In addition to a broad standard assortment of control levers, the company offers specialized solutions designed to customer specifications. In practice, this commonly implies a point of departure in customer requirements, which is subsequently developed by a professional industrial designer and the company's engineers.

Improved functionality, ergonomics, and adaptation to and of customer profiles are important elements of such a process. Adjustments can be made to existing products or new products, according to the needs and wishes of the customer.





MARINE CYBERNETICS AS
 Vestre Rosten 77 • NO-7075 Tiller, Norway
 Tel: +47 72 88 43 30 • Fax: +47 72 88 43 31
 E-mail: contact@marinecybernetics.com
 Website: www.marinecybernetics.com

Marine Cybernetics specializes in providing safety and cost-effectiveness for clients by testing the control systems on ships and offshore installations. The company assesses control systems using Hardware-In-the-Loop (HIL) testing, which is based on its unique CyberSea Simulator Technology. This test method results in a more thorough and relevant assessment of software in the control systems.

Hardware-In-The-Loop Simulation Testing

Independent testing by Marine Cybernetics is an essential element of working towards higher quality for software in control systems. The company's CyberSea Simulator Technology replicates potential problems which can occur during operations at sea, thus testing that control systems are able to manage effectively in any situation according to class and client requirements. A HIL test is done by connecting the control system to a simulator that simulates the ship in normal, abnormal and degraded situations.

Marine Cybernetics offers HIL testing of systems such as dynamic positioning systems (DP), power management systems (PMS), propulsion and thruster control (P&T), ballast systems, etc. HIL tests are carried out on offshore service vessels, drilling vessels, LNG tankers, shuttle tankers and cruise vessels, amongst others.

Benefits of HIL Testing

The benefits of HIL testing include:

- Safer ships and rigs with less incidents caused by software and computer errors
- Reduced cost and risk due to early testing done in the design and engineering phases
- More efficient sea trials
- Less need for potentially destructive testing
- Reduced downtime and risk during operations
- Vessel-specific operator training based on HIL findings, and verification of the vessel's operational procedures

Certified Testing

Marine Cybernetics' HIL test services are carried out according to Det Norske Veritas' (DNV) new Standard for Certification of HIL testing. Oil companies have put HIL into requirement specifications for new charters to increase productiveness, ensure safety and reduce the risk of harming the environment.

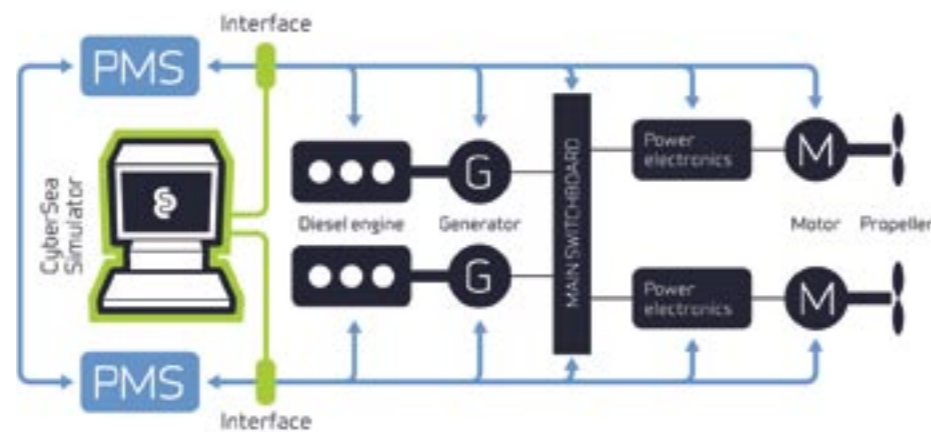

MARINTEK
 PO Box 4125 Valentinlyst • NO-7450 Trondheim, Norway
 Tel: +47 73 59 55 00 • Fax: +47 73 59 57 76
 E-mail: marintek@marintek.sintef.no
 Website: www.marintek.sintef.no

MARINTEK (the Norwegian Marine Technology Research Institute) carries out research, development and technical consulting in the maritime sector for industry and the public sector. The Institute develops and verifies technological solutions for the shipping and maritime equipment industries and for offshore petroleum production.

Main Areas

MARINTEK's main areas of focus are:

- Offshore hydrodynamics
- Marine operations and simulation
- Structural engineering
- Ship technology
- Maintenance technology
- Strategy and logistics
- Energy systems and environment
- e-Maritime

Ship Concepts

MARINTEK has the testing facilities, expertise and analytical tools for the purpose of developing operationally efficient and safe ship concepts. These include:

- Concept development and the testing of hull and propulsion systems
- Propulsion and control
- Manoeuvring and ship handling
- Sea-keeping performance and operational criteria development
- Sea loads
- Structure analysis
- Machinery plant design analysis

1. One of the 500 offshore vessels designed by Rolls-Royce and tested at MARINTEK.
2. Efficient methods for analyses of global marine logistics solutions are developed with support from MARINTEK experts.

Marine Logistics & Ship Operation

An increasingly important requirement in shipping is high-quality organizational performance in logistics and ship operation. To help achieve this, MARINTEK provides:

- Logistics strategy and logistics comparative analysis
- Logistics and fleet optimization
- Management and decision support systems
- Technical condition and performance analysis support
- Qualification testing and computer-based training

Laboratory Facilities

- Ocean basin
- Ship model tank
- Cavitation laboratory
- Marine structures laboratory
- Energy/machinery laboratory

Partners

NTNU (the Norwegian University of Science and Technology) is a cooperative partner of MARINTEK within R&D strategic programmes. MARINTEK is the main supporter of NTNU's "Ship and Ocean Structures" Centre of Excellence. Its focus is on hydrodynamics, structures and cybernetics. A University Technology Centre has been set up by Rolls-Royce, NTNU and MARINTEK within propulsion and control.

MARINTEK, together with NTNU, is one of the strongest civil centres of maritime R&D in the Western world.



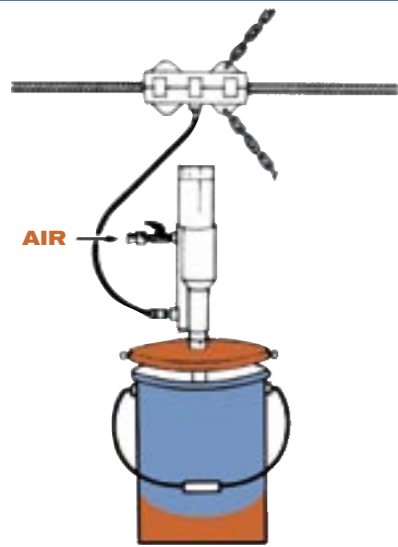

MASTO WIRE-SERVICE AS
MASTO WIRE ROPE LUBRICATOR

MASTO WIRE SERVICE AS
 PO Box 1615 Lundsiden
 NO-4688 Kristiansand S, Norway
 Tel: +47 38 09 70 50 • Fax: +47 38 09 70 53
 E-mail: t.b.krageboen@masto.no
 Website: www.masto.no

Masto Wire Service AS manufactures high-pressure wire rope lubricators specifically designed to extend the life of wire ropes used in the shipping, offshore and onshore industries. Masto lubricators are exported worldwide. Barwil Unitor is the worldwide distributor for the shipping market, together with Masto.

A Single Operation

Conventional lubrication of wire ropes by hand, using gloves, brushes and rags is not only inefficient and time-consuming, but in many cases serves to conceal internal corrosion.

The Masto lubricator forces rust, old lubricant, water and foreign objects out of the rope, scrapes it, and infuses a new heavy lubricant – in one straightforward operation. The heavy lubricant is superior to oil or liquid, as it is retained far longer and does not flow out of the rope as easily.

Simple to Use

A Masto lubricator is easy to use. Split seals are fitted around the rope and clamped in place by the two halves of the lubricating chamber. The unit is then coupled to a high-pressure lubricating pump via a flexible hose, and lubricant is pumped into the chamber until it is full. The unit is anchored by chains, and the wire rope is fed through it.

Three Models

- There are three basic models:
- **MWL 4/35** – Used for wire rope in diameters of 4 to 35 mm.
- **MWL 36/77** – Used for wire rope in diameters of 36 to 77 mm.
- **MWL 77/150** mm lubricates wire ropes from 77 mm up to 152 mm in diameters.

A lubricator for larger rope diameters is available upon special request. The standard chamber material is aluminium, but other metals are available on request. A single set of seals usually lubricates up to 3,000–4,000 m of wire rope.

Used by Bridon International (Certex)

Bridon, the world's leading wire rope manufacturer, uses Masto lubricators in its factories. Since 1990, Bridon has used Masto equipment onsite for maintaining customer ropes. Bridon also distributes Masto products.

References

Masto lubricators are sold worldwide and are used extensively by international shipping companies, including:

- **Canada** – Teekay Shipping Canada Ltd.
- **China** – Cosco Quindado
- **Cyprus** – Athena Marine, Columbia Shipmanagement, Reederei "Nord" Klaus E. Oldendorff Ltd., Unicom Management Services Ltd., V.Ships
- **Denmark** – Maersk
- **Finland** – Fortum Oil & Gas
- **Germany** – Columbus Shipmanagement, Phoenix Reederei, Reederei Ernst Jacob Flensburg
- **Greece** – Ceres Hellenic Shipping, Chandris, Minerva Marine Ltd., Thenamaris Ships Management
- **Hong Kong** – Wallem Ship Management

- **Korea** – Pan Ocean Shipping
- **Kuwait** – Kuwait Oil Tankers
- **The Netherlands** – Confidence Shipmanagement, Smith Fleet Services
- **Norway** – V. Ships, Bergesen dy, Fred. Olsen Lines, Gotaas-Larsen, InterOcean Uglund Management, The Royal Norwegian Navy, Sigvald Bergesen, Stolt Offshore, Westfal-Larsen, Wilh. Wilhelmsen
- **Poland** – Shipolbrosk Gdynia
- **Portugal** – GMM
- **Singapore** – Eagle Shipmanagement PTE Ltd., IMC Shipping Co. PTE Ltd., Mol Tankship Management, Neptune Shipmanagement Services, Nyk Shipmanagement, Pacific Tankers, ROCL Shipmanagement, Thome Ship Management, World Wide Shipping Agency
- **Sweden** – Johnson Shipmanagement, Stena Line
- **United Arab Emirates** – Barber Shipmanagement, International Tankers Management Ltd., Vela International Marine
- **United Kingdom** – Mobil Shipping, Mol Tankship Management, P&O Ferry Master, The Royal Navy, Shell International Shipping, V.Ships
- **United States** – Crystal Cruises, Great White Fleet, Sonsub, Stolt Offshore/Ceanic, Universe Tankships, Inc., Wallem Shipmanagement, Western Geophysical



MIROS AS
 PO Box 364 • Solbråveien 32 • NO-1372 Asker, Norway
 Tel: +47 66 98 75 00 • Fax: +47 66 90 41 70
 E-mail: office@miros.no • Website: www.miros.no

Miros AS is a high-tech company that produces advanced remote sensing equipment for the shipping and offshore industries. The company's products include the WAVEX online directional wave monitoring system for traditional vessels, naval vessels and high-speed craft, MIROS Oil Spill Detection system, altimeters and directional wave and current radar for shore sites, platforms and vessels on locations, as well as meteorological and oceanographic systems and sensors. Miros' quality assurance system complies with NS-ISO 9001.

Directional Wave Monitoring System

The WAVEX directional wave monitoring system can be used on ships sailing at any speed. The system features a bridge display for monitoring wave parameters in real time such as actual wave height, period and direction. WAVEX is a valuable tool for sea state evaluation, for applications such as passage planning and reduction of hull and cargo damage, as the crew can see when to reduce speed or alter the ship's course when sailing in bad weather. For high-speed craft, WAVEX provides information on operational parameters such as significant wave height.

WAVEX can be used as a stand-alone system or as part of a hull monitoring system. The system is compact and can normally use a ship's existing X-band radar antenna for signal input.

Directional Wave & Surface Current Radar

The Miros SM-050 MkIII wave radar is a special-purpose microwave sensor system designed for real-time measurement of directional ocean wave spectra and surface current. It is available in two configurations, one for onshore locations or for fixed platforms, and one that is motion-compensated for floating platforms, FPSOs or ships on location.

Microwave Altimeter

The Miros Range Finder is a special-purpose sensor for measuring wave profiles and air gaps from high-speed vessels and offshore installations. It is very accurate and can differentiate between water and water spray. The Range Finder is also used for ride control input and tide monitoring.

Oil Spill Detection

The MIROS Oil Spill Detection system (OSD) utilizes advanced image processing algorithms for earliest possible oil spill detection. The efficiency of clean-up operations is thereby increased and the extent of environmental impact reduced. MIROS OSD can detect oil spills in complete darkness, enabling 24-hour skimmer operations.

Met-Ocean Systems

Miros has extensive experience in delivering Met-Ocean systems and can supply and integrate any required sensor into its systems. Modular Miros systems are delivered with software and displays tailored to individual operator needs. Miros provides users with real-time and historic data to support:

- Weather centres
- Helicopter traffic control
- Marine operations
- Crane vessel operations
- Synoptic reporting

1. Miros OSD display from a real oil spill showing also drift and wind speed vectors.

2. Miros' WAVEX system is installed onboard SNCM's NGV *Aliso*.

3. Miros' WAVEX system is installed onboard the shuttle tanker *Navion Europa*.





MULTI MARITIME AS
 PO Box 90 • NO-6801 Førde, Norway
 Tel: +47 57 82 84 50 • Fax: +47 57 82 84 51
 E-mail: firmapost@multi-maritime.no
 Website: www.multi-maritime.no

Multi Maritime AS is a privately owned company, established in 1983 and located in Førde in western Norway. A multi-skilled consultancy, Multi Maritime employs a staff of highly qualified technicians and engineers, and has a worldwide client portfolio.

Services

Multi Maritime offers professional – and confidential – consultancy services to shipowners and shipyards. The company’s principal expertise is in specialized vessels, prototypes and innovation. Multi Maritime works closely with its clients at every stage – from first idea, through project development, design and construction to implementation.

Multi Maritime’s services include the following:

- Conceptual design
- Ship design/estimates
- Strength calculations/constructions
- System drawings
- Arrangement drawings
- Piping arrangement and ISO drawings
- Workshop drawings

Experience & Expertise

Multi Maritime’s method is to develop a close and confidential working relationship with each of its clients. The experience and expertise of both partners are combined to create the basis for the most efficient and cost-effective solutions. Multi Maritime’s flexible approach to design and production enables it to meet its clients’ specific goals and requirements. The company’s ongoing investment in research and development equips it with the state-of-the-art design and production skills needed to turn its clients’ projects into reality.

Multi Maritime AS designs most types of vessels, but its three main categories of vessels are represented by the three illustrations on this page.



1. Passenger vessels, represented by the “MM 77 FD” design. The Ro-Ro car ferry will operate between the Danish port of Rømø and the German island Sylt.

2. Icebreakers, offshore service vessels and submersible barges, represented by the “MM 65 ICE” design. The icebreaker will operate at the DeKastri oil terminal near Sakhalin Island in eastern Russia.

3. Cargo ships, represented by the “MM 80 Reefer” design. Six vessels of this design are currently on order.



NATIONAL OILWELL NORWAY AS
 Service Box 401 • NO-4604 Kristiansand, Norway
 Tel: +47 38 19 20 00 • Fax: +47 38 19 23 11
 E-mail: norway@nov.com • Website: www.nov.com

National Oilwell Norway AS is a wholly owned subsidiary of National Oilwell Varco Ltd. National Oilwell Varco is a leading provider for the worldwide oil and gas industry and has been dedicated to providing the highest quality oilfield products and services for more than 140 years. National Oilwell Varco is a single source for all rig equipment, integrated systems, downhole tools and supply chain solutions, and delivers an unlimited range of customer solutions. By constantly developing and acquiring new technologies and services to better serve future customer requirements, National Oilwell Varco will continue to be one of the premier sources for diversified oilfield products and services worldwide.

Lifting & Handling

National Oilwell Varco is a main supplier for lifting and handling requirements. The company offers a comprehensive line of highly engineered equipment, systems and services for offshore construction vessels, fixed and floating production installations, offshore support segments and land applications.

National Oilwell Varco delivers an expansive line of cranes, winches, mooring systems, pipelay and cable lay systems, jacking and skidding equipment and motion compensation systems. In addition, the company’s product line includes FPSO equipment packages, as well as anchor handling tug and supply vessel (AHTS) equipment packages. Backed by quality-driven life cycle management and aftermarket parts and service programmes, National Oilwell Varco provides unmatched lifting and handling solutions.

The comprehensive product line of FPSO and AHTS equipment packages is based on the strength of National Oilwell Varco’s expanded assembly of brand names with international renown:

- Hydralift™ (Norway)
- AmClyde™ (USA)
- Aktro™ (Norway)
- BLM™ (France)
- Procon™ (Norway)
- Molde™ (Norway)
- Stalprodukter™ (Norway)

Their distinguished history of technical innovation and customer satisfaction is now available to customers as a part of a National Oilwell Varco solution.

Additional Norway Offices

- **Cabins & Controls**
 PO Box 8181, NO-4069 Stavanger
 Tel: +47 51 81 81 81
 Fax: +47 51 80 05 47
- **Lifting Equipment & Cranes**
 Grandfjæra 24, NO-6415 Molde
 Tel: +47 71 20 20 20
 Fax: +47 71 20 20 22
- **Mud Systems & Compensation**
 PO Box 168, NO-1386 Asker
 Tel: +47 66 76 07 50
 Fax: +47 66 90 23 53





NAVICO NORWAY AS
 PO Box 475 • NO-1327 Lysaker, Norway
 Tel: +47 67 12 64 00
 Website: www.navico.com

The company Navico was formed through the merger of two of the world's most important players in the field of marine electronics, Simrad and Lowrance. As a key player in the marine industry, Navico develops, manufactures, markets and sells the brands of Simrad, Lowrance, B&G and Eagle, which are distributed in more than 50 countries, all over of the world. Navico has approximately 2,500 employees and is set to reach a turnover of nearly NOK 2 billion in 2006.

Innovative Auto Steering

Simrad autopilots instantaneously adapt to a boat's steering characteristics and to varying sea conditions. The AP35, AP50 Wheelmark-approved, and AP25 are rugged autopilots with a complete range of features for professional mariners. These automatic steering systems can be tailor-made for vessels of all sizes and types.

Intelligent Navigation

With the new GB60 Glass Bridge system, Simrad has taken a big step into next generation navigation solutions. The flexibility of the system enables the user to configure more than 12 monitors in different ways and with any combination of application – vector charts, photos, radars, navigational information, raster charts, 3D, video input and much more may be displayed, all at an exceptionally high resolution for even clearer information on the screens.

ECDIS – IMO-Approved Safety

One of the main features of ECDIS is that it enables paperless operations, using high-quality ENC's for safer navigation. Combining a CS68 ECDIS system with backup (Simrad PLECDIS™), the navigator can utilize a fully approved and redundant high-class electronic navigation system that allows ships to operate without paper charts onboard.

Radar Screen Liferaft Identification

Simrad SA50 is the smallest SART currently available on the market. Its small size and low weight make it ideal for installation in pre-packed liferafts. The special design of the electronics allows the use of a non-hazardous battery, while exceeding the IMO.



1. AP50 Autopilot system.

2. GB60 Glass Bridge system.

3. CS68 ECDIS/PLECDIS Chart system.

4. SA50 SART Search and Rescue Responder.



NOR INSTRUMENTS AS
 Jerikoveien 25 • NO-1076 Oslo, Norway
 Tel: +47 23 14 13 50 • Fax: +47 23 14 13 51
 E-mail: nor.oslo@nor-instruments.no
 Website: www.nor-instruments.no

NOR Instruments AS was founded in 1987 and is the manufacturer of NOR Purifier, a highly efficient method of extracting moisture and gases from hydraulic and lubricating oils. The company also offers valve solutions to the Norwegian offshore and onshore industries, including control valves, safety valves and rupture discs. The company has 27 employees and is located in Oslo (headquarters) and close to the CCB Base at Ågotnes outside Bergen.

The HYDROVAC® Method

The HYDROVAC® method behind the NOR Purifier was developed by NOR Instruments. This method offers high efficiency in extracting water and gases from oil, thereby ridding machinery of contaminants before the development of excessive wear and subsequent by-product build-up. The patented HYDROVAC® method uses a vacuum in combination with air, which expands in contact with warm oil. This air bubble acts as a sponge as it sucks moisture out of the surrounding oil. The vacuum not only ensures the right conditions for water evaporation, but also facilitates the transport of moisture out of the purifier and oil into the purifier.

Applications

The most typical applications of NOR Purifier for the marine/offshore industry are thruster systems (supply, work ships), power units for subsea and topside hydraulics (HPUs), subsea electrical motors (oil-filled) and shore-based maintenance services. These applications cannot afford even insignificant quantities of water to remain in the system. They therefore need the assurance that any intruding water is quickly removed.

Other features of NOR Purifier are:

- Simple method – just plug and play
- Flexible with regard to type of oil
- Few components
- Good price/performance
- Complete oil maintenance with use of optional part

References

Due to its high efficiency in conjunction with water removal from thruster systems, the SH1000 is delivered to most major supply ship companies operating in Norwegian waters as well as major shipping lines. These include Solstad, Eidesvik, Olympiac, Trico, Havila, Island Offshore, Color Line and Cunard. NOR Purifier is often a

preferred brand when water separation is specified to the shipyards; therefore a frame agreement has been entered between NOR Instruments AS and Aker Yards to simplify the acquisition of such units for its newbuildings. NOR Purifier is a preferred water separator also by Rolls-Royce Marine.

On offshore installations, the NOR Purifier is chosen by Statoil, Hydro, ConocoPhillips, Aker Kværner and FMC. Reference installations include Troll C, Ekofisk, Snorre A and Ormen Lange.

1. SH1000 ship version.

2. Dehydration of saturated gear oil, water in emulsion.

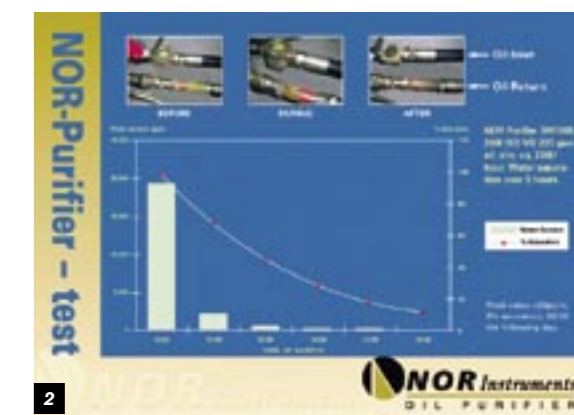



NORAC AS
 PO Box 1593 Stoa • NO-4857 Arendal, Norway
 Tel: +47 37 05 92 50 • Fax: +47 37 05 92 51
 E-mail: sales@norac.no • Website: www.norac.no

Norac is a leading supplier of interior systems for cruise ships, ferries, commercial vessels and offshore installations. Headquartered in Norway, the company manufactures and distributes fire-rated walls, ceiling systems, doors, prefabricated wet units, floating floors, windows and furniture, making Norac a “one-stop shop” for high-quality, affordable interior systems for the maritime industry. Norac products are manufactured with only first-class materials in compliance with the most exacting rules and regulations and Norac’s own strict quality control measures.

Wall Systems

Norac provides wall systems designed to meet the following criteria: quality, flexibility, fire, sound, weight and ease of installation. Based on new requirements for improved acoustic insulation, Norac has developed a series of acoustic walls, which offer documented sound reduction properties of up to 54 dB RW.

Ceiling Systems

Norac manufactures and supplies both suspended and self-suspended ceiling solutions. The ceiling systems are recognized throughout the industry for both their superior acoustic properties and ease of installation. The self-suspended ceiling modules have been designed to avoid structural borne noise and to reduce safety risks associated with loose fire insulation.

Doors

A complete range of doors – including ship-type internal A and B doors, external A-class and weathertight doors, and heavy-duty offshore fire doors up to class H-120. High sound reduction solutions available.

Wet Units

Building on decades of experience and specialized competence, Norac offers fully fitted wet units. The Norac modular wet units are ideal for marine accommodations from cruise ships to offshore installations.

Floating Floors

Norac manufactures and supplies floating floor systems designed for strength, safety, ease of installation and sound reduction properties. The floor system is constructed of galvanized steel cassettes of 3 mm thickness, but is easy to transport and install.

Windows

Norac has developed fire-rated windows with fire class from B-30 up to H-90 in various sizes. The windows offer optimum safety and comfort with onsite-tested sound reduction of 60dB. Norac window systems include a telescopic internal frame for accurate and flexible installation.

Furniture

Norac Marine Furniture (NMF) offers a flexible line of ship’s furniture for conventional ships and offshore living quarters. The furniture from NMF fulfils

today’s requirements of quality, durability and user-friendliness.

External Walls

Norac manufactures specialized internal and external fire walls on behalf of and in cooperation with BD Systems, UK. BD Systems has developed a comprehensive range of fire/acoustic-rated internal panelling and external cladding systems for the outfitting and construction of accommodation units and production/drilling areas. These cover the full range of A, B, C and H-class systems. They have been developed for high performance and durability in the harshest of offshore environments.

For further information, please visit the company’s website: www.norac.no.

	Ships		Offshore		Land based	
	Fire Class	Sound red.	Fire Class	Sound red.	Fire Class*	Sound red.
Wall systems	B10-A02	up to 54dB	B10-A02	up to 54dB		up to 54dB
Ceiling systems	B10-A02	up to 54dB	B10-A02	up to 54dB		up to 54dB
Partitions	A0-A02	high	A0-A02	high		up to 54dB
Floors	B10-A02	up to 54dB	B10-A02	up to 54dB		up to 54dB
Windows	B10-A02	up to 54dB	B10-A02	up to 54dB		up to 54dB
Fire doors	B10	Good	B10	Good		Good

* Fire class according to customer requirements

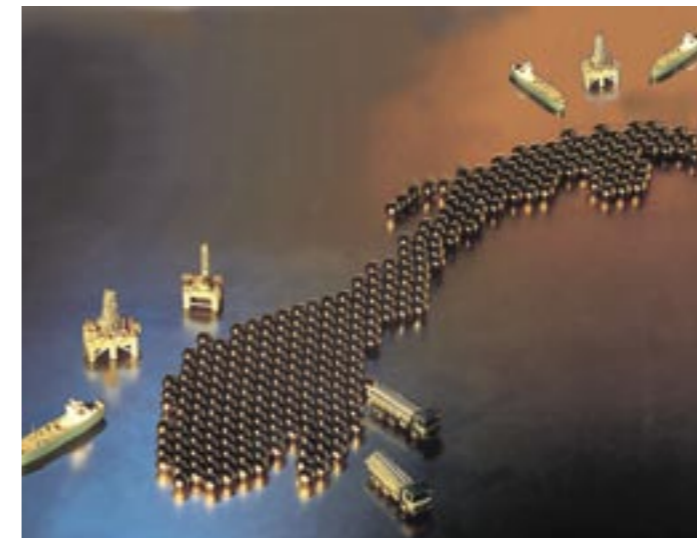

NORSK STÅL AS
 PO Box 123 • NO-1378 Nesbru, Norway
 Tel: +47 66 84 28 00 • Fax: +47 66 84 28 70
 E-mail: firmapost@norskstaal.no
 Website: www.norskstaal.no

Established in 1823, Norsk Stål has long experience in the warehousing of steel and metals. The company currently has twelve sales offices located throughout Norway. With its extensive distribution network, the company has been a natural first choice as a steel and metals distributor in Norway and the company has played a leading role in Scandinavia as a supplier to a range of industries. Norsk Stål has a sales volume of NOK 2 billion and 300 employees.

Industry Sectors

Norsk Stål provides warehousing and pre-treatment of steel and other metals for the following industries:

- Offshore
- Shipbuilding
- Building and construction
- Mechanical

Products & Services

The company offers a variety of pre-treatment services, such as shot blasting and priming as well as saw cutting, flame cutting and plasma cutting. Norsk Stål’s products include the following:

- Hot-rolled steel plates
- Hot-rolled steel bars
- Hot-rolled steel channels, I and H sections
- Hollow sections and tubes (hot finished and cold formed)
- Bright steel
- Cold-formed special products

- Sheets and coils (hot rolled, cold rolled and coated products)
- Building and construction products (reinforcement steel and special products)
- Expanded metal, gratings and perforated products
- Aluminium (plates, strip, bars and special products)
- Metals
- Stainless steel (sheets, plates, coils, bars, tubes and hollow sections)

Prompt Export Deliveries

Norsk Stål’s centrally located warehouses in eastern Norway ensure efficient deliveries to Russia and the Baltic Region.

Warehouse Quality

In carbon steel, Norsk Stål can supply material according to the following specifications:

- Shipbuilding grades according to DNV with 3.2 quality document
- Merchant grades according to EN 10025 with 2.2 and 3.1 quality document
- Offshore grades according to EN 10225 with 3.1 quality document

Quality documents can be delivered with materials, sent electronically or filed by Norsk Stål. The company is certified in compliance with NS-EN ISO 9001:2000





ODFJELL ASA
 PO Box 6101 Postterminalen • NO-5892 Bergen, Norway
 Tel: +47 55 27 00 00 • Fax: +47 55 28 47 41
 E-mail: bgo.mail@odfjell.com
 Website: www.odfjell.com

Odfjell is a leading company in the global market of transporting chemicals and other speciality bulk liquids, as well as providing related logistical services. The company owns and operates parcel tankers in global and regional trade, and a number of strategically located tank terminals. Odfjell is listed on the Oslo Stock Exchange and has an annual turnover of about \$1 billion.

Parcel Tankers

The deep-sea and regional transportation of chemicals and other liquids is Odfjell's core business. The company has unprecedented experience in this complicated field of transportation. Its operations are fully integrated, with dedicated functions for chartering, operation and ship management. Odfjell's specialized fleet consists of 123 ships, including newbuildings on order, with a total capacity of about 3.4 million dwt.

Tank Terminals

Odfjell's terminal operations yield synergies with its transportation activities and improve quality and efficiency throughout the transportation chain. The company has direct investments in wholly owned tank terminals in Rotterdam and Houston, as well as in partially owned terminals in Singapore, Onsan in Korea, and two terminals in China. Odfjell also works closely with seven terminals in South America through associated companies.

Prospects

Odfjell's strategy is to continue developing its position as a leading logistics service provider for customers worldwide. The company aims to maintain its position through efficient and safe operations. Odfjell's long-term newbuilding programme consists in total of 30 new ships, with deliveries through 2012. The new ships will mainly replace some of the company's older chemical carriers.



Marine Group
 Ing Per Gjerdrum AS

PG MARINE GROUP – ING PER GJERDRUM AS
 Nye Vakaas Vei 28 • NO-1378 Nesbru, Norway
 Tel: +47 66 77 56 00 • Fax: +47 66 77 56 01
 E-mail: pg-pumps@pergjerdrum.no
 Website: www.pg-marinegroup.com

PG Marine Group is based on a global partnership between the company Ing. Per Gjerdrum AS and leading international brands within their specific fields of operations. Fully Norwegian-owned and managed from Oslo, the company is an independent engineering and systems-integrating entity, with specialized manufacturing of core products. The group's mission is to meet demands in the global marine & offshore markets with innovative solutions and products, as well as serve as a complete systems provider for liquid handling processes.

Founded in 1982 as a pump supplier for the Norwegian maritime industry, the company's evolution followed hand-in-

hand with the technological development of the North Sea offshore market. As these technologies and businesses

gradually became more global, PG Marine Group made its way out into international waters and markets.

Cargo Pumping and Fire Fighting Solutions

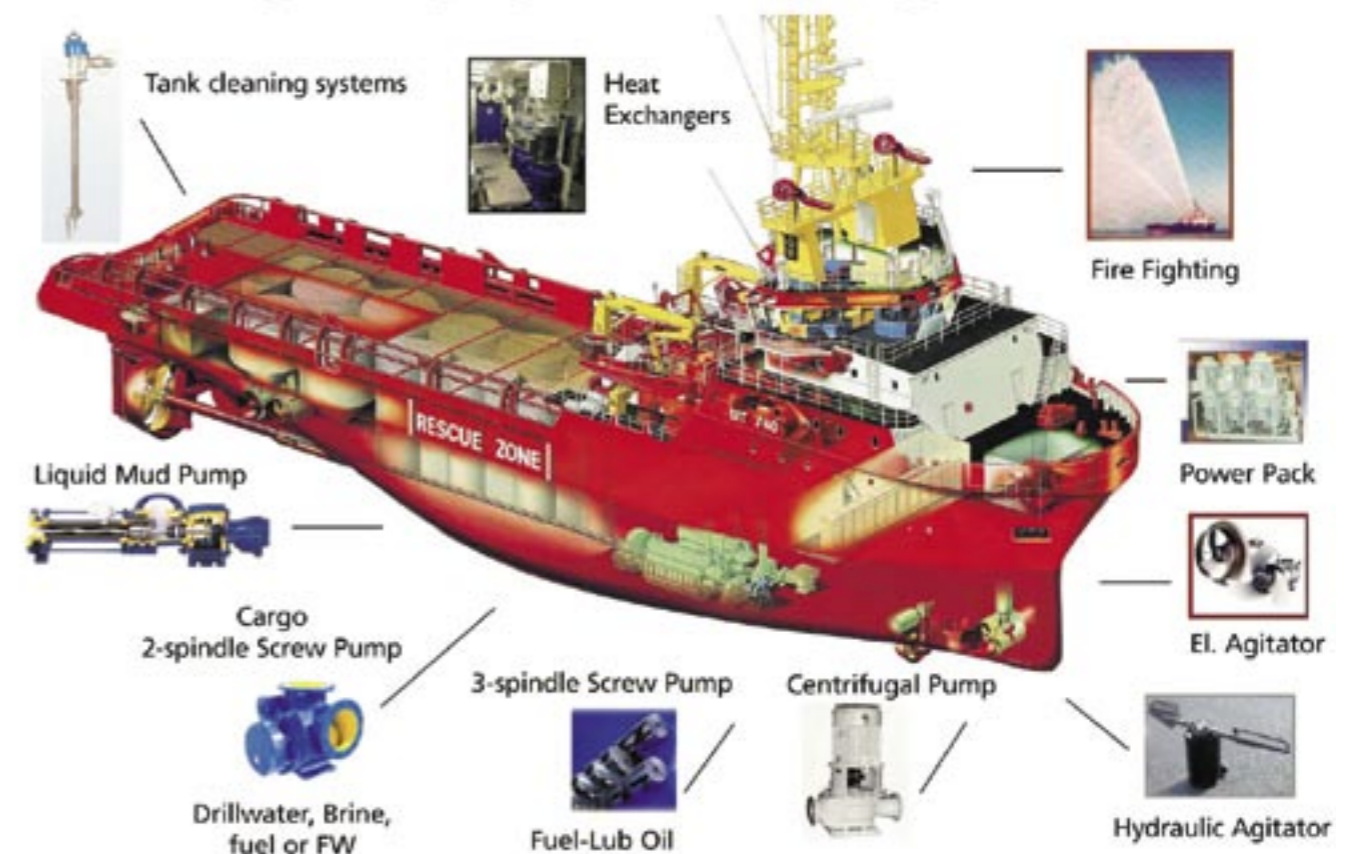





RAPP BOMEK
COMMITTED TO INNOVATING THE INDUSTRY

RAPP BOMEK AS
NO-8037 Bodø, Norway
Tel: +47 75 59 16 00 • Fax: +47 75 59 16 10
E-mail: office@rappbomek.com
Website: www.rappmarine.com

Rapp Bomek AS is Norway's largest manufacturer of advanced technology fireproof and explosion-proof doors for the offshore petroleum industry. With origins dating back to 1864, Rapp Bomek is one of Norway's oldest companies within marine mechanical engineering. The company has manufactured ship equipment mainly for the European market since 1967. Rapp Bomek AS manufactures and provides first-class equipment for all kinds of ships, exploration rigs, and fixed and floating production platforms at competitive prices and with short delivery terms. The complete product range makes the company one of the leading manufacturers of such equipment.

Fire-Rated Doors

Rapp Bomek fire doors are tested according to all applicable specifications and are type-approved by Det Norske Veritas (DNV), American Bureau of Shipping, Lloyd's Register of Shipping and the US Coast Guard for use on fixed and floating platforms. The doors are manufactured under a strict QA system in compliance with ISO 9001, and those delivered to platforms in the North Sea continue to perform well after more than 25 years in a harsh saline environment.

Watertight Hinged Doors

Rapp Bomek watertight doors are developed to meet the requirements of Solas II-1/20-2 reg. 6 and the Stockholm agreement. The doors are tested according to these guidelines and are approved by DNV.

Weather-tight Hinged Doors

Rapp Bomek weather-tight doors are reinforced to meet the strength requirements for ship bulkhead. The doors are fire-tested to A60 according to IMO.

Selection of Products

Doorleaves and frames of mild steel, stainless steel or aluminium are available, and Rapp Bomek doors include several ratings and types:

- Hinged and sliding
- Single and double-sized
- Light-duty A0/A60 rated
- Super-light-duty A0/A60 rated
- Medium-duty A0/A60 rated
- Heavy-duty A0/H120 rated
- Combination doors, fire-rated and weather/watertight
- Spray-tight doors
- Pneumatically operated
- Hydraulically operated
- Customer specified

Hatches

Rapp Bomek manufactures a wide range of hatches for the maritime sector. The company's hatches are tested according to all applicable specifications, and include the following:

- Watertight hatches – Up to 50 m water pressure from outside and 40 m from inside
- Watertight A60 flush hatches
- Weather-tight flush hatches
- Rope hatches
- Tank cleaning hatches

- Inspection hatches
- Access hatches
- Ventilation hatches
- Customer specified

Mooring Equipment

Rapp Bomek's mooring equipment includes roller fairleads (St Lawrence type), Panama chocks (welded types), bollards according to NS standards, guide rollers, chain stoppers and rope drums.

Emergency Towing System

Rapp Bomek has developed a safe, economical emergency towing system that complies with IMO rules for tankers above 20,000 dwt. The light, compact system is stowed on deck in a watertight compartment fixed to the deck, with no wires, chains or ropes to get in the way during normal ship operation.

1. A60 watertight combination door. Water pressure: 5 m inside, 8.5 m outside.

2. Watertight hatch. Water pressure: 40 m inside, 50 m outside.

3. Roller fairleads.





RAPP HYDEMA
COMMITTED TO INNOVATING THE INDUSTRY

RAPP HYDEMA AS
Burøyveien 31-33 • NO-8037 Bodø, Norway
Tel: +47 75 55 01 00 • Fax: +47 75 55 01 11
E-mail: office@rapphydema.com
Website: www.rappmarine.com

Rapp Hydema AS, the oldest member of the Rapp family, was founded in 1907. The company is located in the town of Bodø in Norway and has 80 employees. The Arctic location has provided a unique opportunity to develop and manufacture equipment for the marine sector. Today hydraulic towing, research and trawl winches as well as hydraulic and electric winches for special application within the offshore industries (including control and monitoring systems) are among Rapp Hydema's most important product areas. Total engineering and supervision are available for all products, and the company offers maintenance and service worldwide.

Offshore Winches

A new generation of hydraulic and electric winches for the offshore industry has been developed to meet the demand for deepwater operations.

Product range:

- ROV winches
- Traction winch system
- Heavy lift winches
- Control system with active heave compensation (AHC) systems
- Service and service agreements

Towing Winches

Rapp Hydema has developed a new medium-pressure hydraulic winch system, which includes in-house produced drive units. The winch motors operate with 20–30% lower pressure than previously produced units, extending the lifetime of the motors and the entire hydraulic system. The company's new range of heavy-duty towing winches is adaptable to virtually all towing requirements.

Product range:

- Tug and anchor-handling winches
- Tugger winches
- Capstans
- Monitoring systems
- Hydraulic systems

Research Winches

Rapp Hydema is the world's leading supplier of winches for research applications. This includes special electrical cable winches or deep-sea winches to handle sophisticated scientific equipment. An integrated computerized control and monitoring system is also available.

Product range:

- Traction winch system
- Hydrographic winches
- CTD winches
- Geological winches
- Umbilical winches
- Monitoring system (PTS Pentagon Research)

Multi-Purpose Winches

Rapp Hydema's comprehensive and flexible production range makes it easy to adapt or modify any standard winch range to specific applications.

Product range:

- Auxiliary winches
- Hydraulic systems

Marine Export Markets

Rapp Hydema exports to the following markets:

- Australia
- New Zealand
- United States
- Korea
- Europe
- Middle East
- South Africa
- South America

1. Anchor and mooring winches: Tricing winch.

2. A tug and anchor-handling winch.

3. Research winches: Umbilical winch.



REGATTA AS
 Borgundfjordveien 80 • NO-6017 Ålesund, Norway
 Tel: +47 70 17 69 00 • Fax: +47 70 17 69 01
 E-mail: office@regatta.no • Website: www.regatta.no

Regatta has developed and manufactured a broad range of floatation products for close to 50 years, and is one of Europe's leading producers of buoyancy aids and a variety of floatation products.

Products & Markets

Regatta produces floatation and marine safety products both for the recreational and industrial markets. The company is an international actor with a comprehensive and varied line of products for the maritime industry. The products are especially relevant for cruise lines, shipowners, shipyards, and the fishery and offshore branches.

Innovation in its various product segments has been, and always will be, a continuous process of high priority for Regatta. Safety, freedom of movement and comfort under all conditions are the company's quality goals. Production of the company's SOLAS products is supervised in accordance with the European Maritime Directive. Regatta cooperates closely with certification and testing authorities around the world.

Product Portfolio

- Life jackets
- Buoyancy aids
- Inflatable lifejackets
- Workvests
- Flotation jackets
- Flotation suits
- Oilskin with flotation
- Immersion suits

For further information on Regatta and its significant product range, visit www.regatta.no

1. Thermo Cruise, Adult SOLAS also available as child (EN 395), baby and crew sizes.
2. Kon-Tiki Royal US, Adult. Available as SOLAS or US Coast Guard-approved.
3. Challenger Offshore 150N (available as 275N) SOLAS and flotation suit Offshore 957 (50N).
4. Regatta Fisherman, oilskin gear with flotation in the trouser (50N). EN 393 approved.
5. Workvest 401 50N (available as 150N and 200N), self-extinguishing PVC buoyancy foam.
6. Flotation jacket Harbour 907. Approved according to EN 393, EN 533-1 "Standard for limited flame spread" and EN 471-Class 3 "Standard for visibility".
7. Regatta Immersion suit, high-quality neoprene suit. Approved by Lloyd's Register.

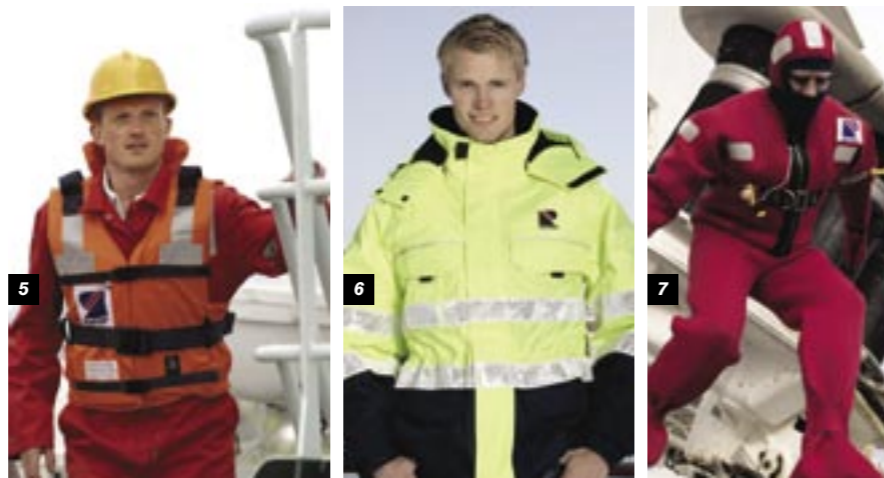
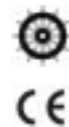

ROLLS-ROYCE MARINE
 PO Box 160 • NO-6067 Ulsteinvik, Norway
 Tel: +47 70 01 40 00 • Fax: +47 70 01 40 05
 E-mail: commercial.marine@rolls-royce.com
 Website: www.rolls-royce.com

Rolls-Royce is one of the largest international suppliers of marine technology, products and systems. The Rolls-Royce Marine division has more than 7,000 employees in 25 countries, an annual turnover of some \$1.7 billion and serves both the naval and commercial sectors. The Marine division is largely based in Scandinavia.

The Force in Marine Solutions

Rolls-Royce Marine specializes in ship design and the design and delivery of propulsion, positioning, manoeuvring, motion control and ship's systems. The company is one of the world's foremost suppliers of marine propulsion systems, deck machinery and steering and stabilizing systems for the offshore, merchant and naval segments of the global marine market.

Ship Design & Ship's Systems

The company places great emphasis on fulfilling customer requirements – often designing and developing vessels before customers request them – and creating innovations that anticipate future demands. Its UT and NVC ship designs are built worldwide.

Rolls-Royce system solutions include fully integrated ship's equipment packages in which the company provides designs and relevant documentation, delivery coordination, and guarantees of high quality and low life-cycle costs. It also offers a wide range of consultancy services, ranging from initial design and financing to ship's equipment supply and planned maintenance.

Rolls-Royce Product Range for the Marine Market

- Rauma Brattvaag – Deck machinery
- Ulstein Hinze – Rudders
- Ulstein bulk handling systems
- UT-Design – Design
- NVC-Design – Design
- UMAS – Automation
- MT30 – Gas turbines
- Bergen – Diesel engines
- Brown Brothers – Stabilizers
- Interling – Stabilizer systems
- Tenfjord – Steering gear
- Frydenbö – Steering gear

- Mermaid – Podded propulsors
- Ulstein Aquamaster – Azimuthing thrusters
- Kamewa – FP propellers and waterjets
- Kamewa Ulstein – CP propellers and tunnel thrusters

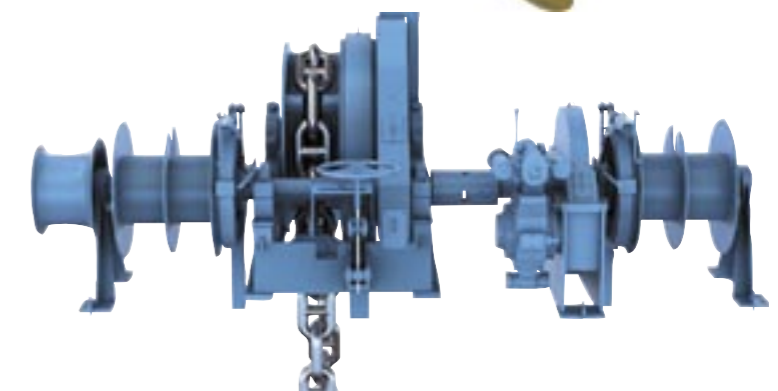
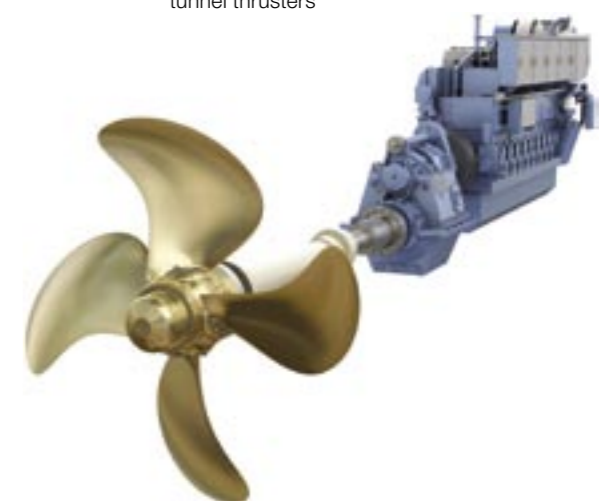



SCANDINAVIAN ELECTRIC SYSTEMS
 PO Box 80 Godvik • NO-5882 Bergen, Norway
 Tel: +47 55 50 60 70 • Fax: +47 55 50 60 52
 E-mail: ses.mail@scel.no • Website: www.scel.no

Scandinavian Electric Systems (SES) is a system house and producer of innovative electrical propulsion systems, components and services for ships within the low-voltage area. SES's systems and products are installed in several different ship types. The company has more than 3,000 references in the marine market and employs 150 people both in Norway and internationally. In addition to its know-how and experience, the company has a philosophy of quick response times, flexibility and service.

Areas of Expertise

- System, design and product development
- Rotating electrical machines
- Drives and other starting equipment
- Engineering
- Production
- Supervision of total projects
- Training
- Testing
- Commissioning
- Total system calculations (short circuit levels, electrical balance, power flow, THD, starting current and voltage drop)
- After-sales services

SES Systems & Products

- Diesel-electric propulsion systems and multi-purpose propulsion solutions
- Generators up to 4,500 kVA
- Main and emergency switchboards
- Electric motors and starter arrangements up to 4,500 kW per unit
- Double-jacket, water-cooled motors, 250–3,000 kW range, known for their compact volume, low vibration, low noise and excellent electrical properties
- Active Front End converter technology for diesel-electric propulsion, eliminating the need for large and heavy transformers. THD levels lower than 4%.
- Frequency converters with software; water and air cooled up to 4,500 kW
- Frequency converter drive systems, including software, for propulsion, electric winches and cranes

- Power management systems
- Black-Out Prevention (BOP) systems
- Clean power systems (rotating converters/static converters)



1. One of the world's largest seismic vessels, with a total generator power of 16,800 kVA and a SES Active Front End propulsion system.

2. The new MT 6010 innovative offshore supply design with a diesel-electric propulsion system from SES, designed for high reliability.

3. Double-jacket, water-cooled motor – 2,200kW.

4. Water-cooled frequency converter – Active Front End (AFE).

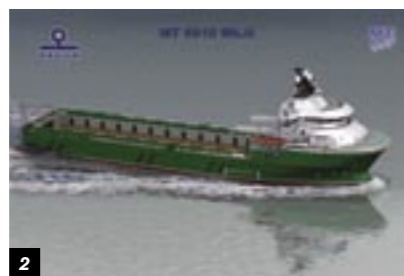

SCANSHIP ENVIRONMENTAL AS
 Kanalveien 4 • NO-3101 Tønsberg, Norway
 Tel: +47 33 01 64 00 • Fax: +47 33 01 64 01
 E-mail: post@scanship.no • Website: www.scanship.no

Scanship Environmental supplies systems for the treatment of dry garbage, food waste, wastewater and bio sludge. Its Total System Concept includes incinerators, recycling equipment, vacuum food waste treatment, advanced wastewater purification and bio sludge driers. Scanship was one of the first companies to obtain an Alaska-approved advanced wastewater system with bio sludge dryer, which also holds Det Norske Veritas' (DNV) approval. The company has supplied advanced treatment systems to more than 55 cruise ships, including some of the world's largest. Scanship offers onboard service and operational assistance through its skilled team of service engineers and its two-way remote monitoring and diagnostics system. Scanship's headquarter is in Norway, while there is a subsidiary for manufacturing in Lithuania and a service and sales subsidiary in Florida, USA.

Total System Concept

As the cruise ship industry gets increasingly environmentally sound, Scanship's Total System Concept allows ship owners to feel confident that their ships will remain within the current emission requirements. The company's systems are controlled by innovative and advanced computer systems, including web-based remote monitoring and diagnostics. By choosing a Total System Concept, there is a single point of contact for multiple systems throughout an installation, and fewer system interfaces between the environmental system and the ship.

Waste Treatment Production Line

Scanship products are based on maritime experiences gained since 1993. The company's continuous improvement and development opens up new possibilities for cost efficient and sustainable solutions, which include:

- **Incinerator systems, 600–2,000 kW** – These incinerators are designed with the very latest technology in multi-chamber, semi-pyrolysis with flue gas emissions within IMO-MARPOL regulations. The incinerators are capable of meeting current and future air emission demands.
- **Food waste systems** – Scanship has developed an efficient vacuum system for collecting, transporting and further processing of food waste from the numerous galleys onboard.
- **Wastewater systems** – Scanship's DNV-approved advanced wastewater system treats all types of contaminated water onboard – giving a crystal clear treated effluent.
- **Bio sludge treatment system** – This system is based on proven technology for transferring liquid bio sludge into a dry stable product. This ensures a proper final treatment and secures the product's environmental fate.

- **Recycling systems** – These are designed to recycle garbage by compacting aluminium cans, paper, plastics and crushed glass.

Markets

Traditionally, Scanship has supplied most major cruise liners. However, a down-scaled product line is increasingly being requested by other maritime markets. Consequently, Scanship is now further sharpening its market ambitions to go beyond current markets.

Service & Sales Subsidiary

Scanship Americas Inc.
 5719 NW 158th St.
 Miami, FL 33014
 USA
 Tel: +1 305 512 8440
 E-mail: mailUSA@scanship.no





SERVOGEAR AS
 NO-5420 Rubbestadneset, Norway
 Tel: +47 53 42 39 50 • Fax: +47 53 42 39 99
 E-mail: main.office@servogear.no
 Website: www.servogear.no

Servogear AS is a leading manufacturer of controllable-pitch (CP) propeller systems for fast vessels. The company has delivered some 1,250 propulsion systems worldwide for most types of fast vessels, including pilot boats, police/customs boats, lifeboats, ambulance boats and yachts, as well as mono-hulled and catamaran passenger vessels.

Servogear Ecoflow Propulsor™

Designed as a complete unit, the Servogear Ecoflow Propulsor™ offers optimal performance while keeping noise and vibrations to a minimum. The system provides:

- CP propellers
- Reduction gearboxes
- Shaft brackets
- Effect rudders
- Stern tubes
- Propeller tunnel designs
- Power range of 300–4,000 kW
- Speeds up to 50 knots

CP Propellers

At Servogear, regular development and extensive experience with successful operations has resulted in a simple, yet technically advanced CP propeller. The company's propeller blade design employs the latest technology and computer programs. During recent years, Servogear CP propellers have been further developed from medium-speed CP propellers to Super Slow Running Propellers (SSRP), offering higher efficiency and comfort. This development has been made possible

due to Servogear's unique propeller tunnel design, which allows for larger propeller diameters without increasing the shaft inclination and/or draft.

Reduction Gearboxes

Specifically designed for high-speed craft, Servogear gearboxes fulfil the need for high torque, low weight and space efficiency. Each gearbox features an integrated hydraulically operated clutch and a servo system to actuate the propeller pitch. The gearboxes are type approved by DNV, and are available in several configurations, including a twin-input/single-output version (one engine aft).

Propeller Tunnels

The Servogear Ecoflow Propulsor™ features a unique propeller tunnel design which affords vessels hydrodynamic advantages as well as reduced hull resistance and draft. The tunnel is integrated into each hull above the shaft and CP propeller.

Performance & Reliability

- The Servogear Ecoflow Propulsor™ offers:
- Excellent manoeuvrability in all conditions
 - Powerful towing capacity
 - Reliability due to simple, solid design
 - Optimal engine performance
 - Low fuel and maintenance costs
 - Long working life



1. Servogear delivers propulsion systems for a wide range of fast vessels.

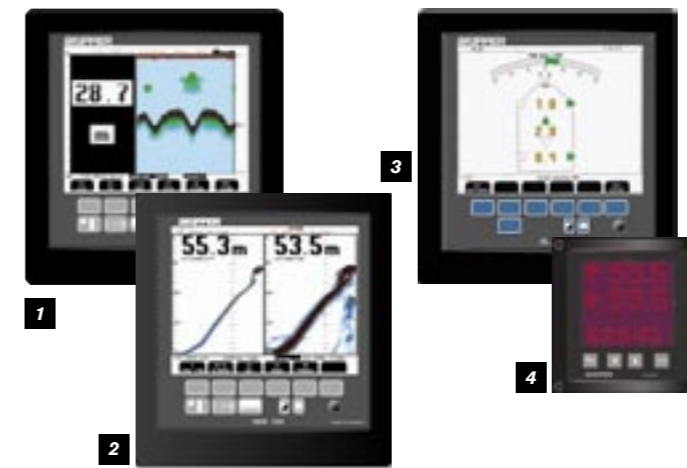

SKIPPER ELECTRONICS AS
 PO Box 151 Manglerud • NO-0612 Oslo, Norway
 Tel: +47 23 30 22 70 • Fax: +47 23 30 22 71
 E-mail: skipper@skipper.no • Website: www.skipper.no

SKIPPER Electronics AS has supplied marine electronics worldwide for over 30 years. The company's main products include hydroacoustic systems for navigation, fish finding and surveying.

User-Friendly, High-Tech Equipment

Echo sounders and speed logs are SKIPPER's main products. Developed with the latest technology and the company's extensive expertise in hydroacoustics, these user-friendly products offer versatile installation and all of the most important features required on modern vessels. All models are approved according to relevant regulations and bear the Wheelmark mark of conformity.

SKIPPER Navigation Echo Sounders

The range of this product extends from traditional recording paper presentations to models with the latest, high-resolution colour LCD display. This selection ranges from the basic "IMO Sounder" to a sophisticated dual-channel system for ships with requirements related to special operations and depth ranges of 5,000 metres. There is also a full range of bottom parts, including transducer tanks and gate valves made to fit specific customer requirements.

SKIPPER Speed Logs

Models range from low-end, single-axis EM logs to dual-axis docking logs for high-end users. All models give full flexibility of installation methods, from tank mounting to gate valves for single or double-hull ships.

Additional Products & Services

- Fish-finding equipment
- OEM production

Echo Sounders:

1. SKIPPER GDS101 navigation echo sounder.
2. SKIPPER GDS102 navigation echo sounder.

Speed Logs:

3. SKIPPER DL 850 Doppler/docking log.
4. SKIPPER EML224 EM log.

5. SKIPPER IR300 digital speed repeater.
6. SKIPPER IR301 digital depth repeater.

7. Bottom installations for echo sounders and speed logs. Tank and gate valve for single/double hull; ice protection provided when required.

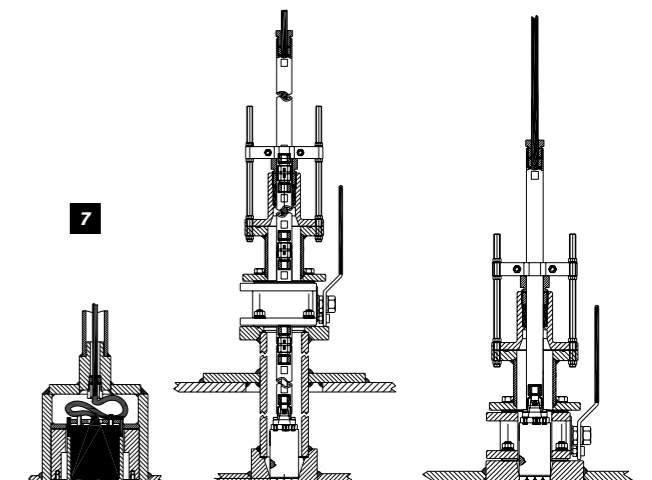



AS SØRLANDETS ALUMINUMPRODUKTER
 Mjåvannsveien 35 • NO-4628 Kristiansand, Norway
 Tel: +47 38 18 52 00 • Fax: +47 38 18 20 86
 E-mail: sales@norsap.no • Website: www.norsap.no

Established in 1969, AS Sørlandets Aluminiumprodukter (SAP) specializes in operator chairs for vessels of all types and sizes. The company has developed its popular line of Nor-Sap chairs and deck rails in close cooperation with end users, and exports its products for use onboard vessels and offshore installations around the globe.

Quality & Comfort at Sea

SAP emphasizes comfort, quality and versatility in its collision-tested Nor-Sap operator chairs. The chairs are designed to withstand the harsh

maritime environment while offering a high degree of ergonomic comfort. Most models are available in different sizes and configurations and all can be combined with various deck rails. The Control and

Offshore chairs allow installation of various customer-specific controls in the armrests. Black leather upholstery is standard for Nor-Sap chairs, but many other colours or fabrics are available.



NS 1500 Comfort



NS Offshore MX
with deck rail



Star Information Systems AS

STAR INFORMATION SYSTEMS AS (SIS)
 Stortorvet 5 • NO-0155 Oslo, Norway
 Tel: +47 22 47 69 10 • Fax: +47 22 47 69 19
 E-mail: sales@sismarine.com
 Website: www.sismarine.com

Star Information Systems AS (SIS) is a professional supplier of integrated fleet and ship/rig management software that contains modules for budget and cost control, work planning, messaging, projects, equipment, spare parts, crew, addresses, documents, forms, event and insurance handling, requisitions, purchasing, e-commerce and replication of data between ship/rig and office. The software is linked all the way from the ship to the suppliers via the e-procurement solution.

Main Products

Star Information Systems AS's main products include:

Star Information & Planning System

This is a complete fleet management suite integrated in one central database and local databases onboard or at site offices. The databases are updated by replication between the ship/rig and office utilizing tailored reports and KPIs for management and officers. SIS also has clients with one central database in office with their ships/rigs online.

Star Central Purchasing System

A system for management and staff that contains modules for purchasing, contracts, transportation, warehouse, budget and management reports.

Star Safety

Star Safety is an integrated event, document and insurance package for people onboard for recording accidents and near misses. It is also for use by the central insurance department and safety staff in the office.

Star Maintenance

This contains modules for work planning, control, inventory, requisition and purchasing onboard and for the superintendent and technical management in the office.

Star Project

Star IPS is the ultimate docking, repair and conversion module. Users can create specifications, compare quotes, prepare for docking, change orders and report back to Star Maintenance.

SISCommerce

SISCommerce is an e-commerce solution for the maritime industry. The use of electronic interchange will lead to major improvements in quality in the supply change process, which brings about considerable cost savings and enables improvements for shipping/offshore companies and vendors.

Agents

The company has agents in Australia, Brazil, Canada, Denmark, Dubai, the Netherlands, Singapore and the UK.

For agent contact information, please visit www.sismarine.com





STEINSVIK AS
 NO-5563 Førresfjorden, Norway
 Tel: +47 52 75 47 00 • Fax: +47 52 75 47 01
 E-mail: post@steinsvik.no
 Websites: www.steinsvik.no / www.flexibrIDGE.no / www.orbitaquacam.no

Steinsvik AS is proud to introduce FlexiBridge. The FlexiBridge revolutionizes work on the bridge. It opens up the work space so the entire bridge becomes brighter, more functional and aesthetically pleasing.

FlexiBridge

FlexiBridge is a bridge solution for the future. The bridge is flexible with adjustable monitors and instrument panels. The monitors can be turned and adjusted around the x, y and z-axes and can be easily adapted to avoid reflective light or to suit the specific operation, such as the berthing of a vessel. The front instrument panel can be tilted to provide a better view of the recessed screen.



Modular System

The modular system of FlexiBridge allows for a wide variety of custom-built bridge arrangements. The modular concept facilitates the introduction of new monitors, such as widescreen monitors. Pre-assembled components in enclosed units allow quick and easy installation to keep costs down. Pre-assembly at the yard or manufacturer also means avoiding difficult working conditions onboard with associated damage and dust problems. Consoles can be upgraded or replaced by replacing the instrument panel only.

Revolutionary Bridge Solution

The distance between monitors improves visibility considerably and therefore safety as well, while the front instrument panels are at a more natural working height. The bridge offers the added advantage of reduced vibration and resonance problems. It is adapted to modern designs with large floor-to-ceiling window panes, and meets the new requirements for conventional vessels, offshore and fishing vessels. This in turn simplifies placement and installation. Improved ergonomics means a better working environment and greater job satisfaction.



STROMME ASA
 PO Box 31 • NO-1305 Haslum, Norway
 Tel: +47 67 52 60 60 • Fax: +47 67 52 60 50
 E-mail: stromme@stromme.com
 Website: www.stromme.com

STROMME NME AS
 PO Box 244 • NO-5480 Husnes, Norway
 Tel: +47 53 47 95 00 • Fax: +47 53 47 34 99
 E-mail: nme@nme.no

Stromme is constantly aware of its clients' greatest concern – to save time and make money. That is why the company guarantees its clients a swift response, delivery as agreed and a complete range of quality equipment and supplies.

Marine Equipment

Stromme manufactures and supplies a complete range of quality marine products, including quality Stromme-branded products.

Equipment

- Lifeboats, rescue boats, davits, immersion suits, FRS equipment, cranes, Fi-Fi pump sets, fenders, reverse osmosis plants, compressors, cleaning systems, tools and workshop equipment, and various maritime/offshore equipment

Services

- Stromme also offers worldwide services for all kinds of equipment, ensuring its customers trouble-free operations.
- Fire, Rescue and Safety service (FRS)
 - Mechanical and electrical repairs
 - Steel and pipe fitting at anchorage in port
 - In-place generator cleaning

Marine Supply & Logistics

Worldwide availability and a complete range of products is the key to efficient supply and logistics. Stromme's worldwide presence ensures its customers precise delivery of all the supplies and spare parts they need – wherever and whenever they go.

Supplies

- Provisions, galley and bonded, deck and engine stores
- Electrical, navigation and safety equipment
- Medical supplies
- Carpentry, upholstery and refurbishment
- Spare part handling, warehousing and logistics
- Port services – cash to master, crew, mail, etc.

Spare Parts

- Eurospares Division
- Leading supplier of OEM and/or equivalent spare parts for European-made marine equipment

An updated reference list is available at www.stromme.com.

Stromme Branch Offices

United Kingdom, the Netherlands, Germany, Poland, France, Spain, Singapore and the United States.

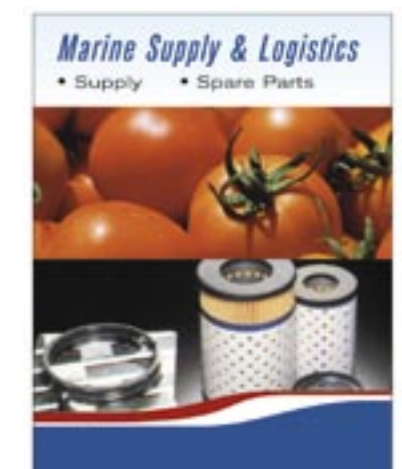



HYDEX. SYLINDERTEKNIKK

SYLINDERTEKNIKK AS
 PO Box 97 Kalbakken • NO-0902 Oslo, Norway
 Tel: +47 22 91 75 20 • Fax: +47 22 91 75 21
 E-mail: post@syinderteknikk.no
 Website: www.syliderteknikk.no

Since Syinderteknikk AS was established in 1994, the company has developed into one of the market's leading producers of hydraulic cylinders. From its office in Oslo the company is able to serve all of Norway with speed, efficiency and excellent service.

Product Line

Sylinderteknikk delivers cylinders to the mobile, marine, offshore and food industries, in addition to subsea installations.

The company's product line includes single- and double-acting telescope, jack and special cylinders in many sizes and designs. These include:

- Twist pitch up to 1,200 metres (telescope up to 42,000 metres)
- Diameter from 20–600 mm
- Pressure areas up to 1,220 bar
- All entry connection types
- Cylinders with magnetic pistons for position determination, inductive transmitters and transducers
- Steel, stainless, titanium, aluminium and brass materials
- Cylinders in accordance with ISO/DIN norms
- Ventilators, hand pumps, mini aggregates and standard aggregates.

Service & Production

Sylinderteknikk has its own service and production workshop and technical staff. This allows the company to be quite flexible with regards to delivery times and technical solutions. It makes custom-made deliveries in the following areas:

- New buildings, from prototype to serial production
- Service
- Speedy deliveries in the case of engine breakdown/trouble
- Repair and rebuilding of all types/makes of cylinders
- Delivery of spare parts, sealing materials, rods and pipes



TAMROTOR MARINE COMPRESSORS AS
 Prof. Birkelands vei 24 D • NO-1001 Oslo, Norway
 Tel: +47 815 21 213 • Fax: +47 815 21 214
 E-mail: mail@tmc-compressors.com
 Website: www.tmc-compressors.com

Whatever the size of the vessel, TMC is able to address all compressed air needs. The company supplies compressors with a capacity ranging from 30 to 4,000 m³ per hour.

Tamrotor Marine Compressors (TMC) is one of the world's leading suppliers of compressed air systems for marine use. The product range consists of screw compressors, air dryers and filters for any type of compressed air, including oil-free air. TMC has a worldwide service, spare part and sales network.

TMC Pioneered the Marine Screw Compressor

- Engineered to withstand 50°C ambient temperature
- Small footprint – about a third of the size and weight of a traditional system
- Rich in features that reduce life-cycle costs
- Clean – producing virtually oil-free air
- Low noise level
- TEMPEST® innovation – 30% fewer parts

- Easy to install and service
- Designed for extended air end lifetime and less wear
- Marine-approved components
- Backed by TMC's global service and aftersales network



1. TMC Smart Air® energy-saving frequency controlled compressor.

2. New in 2007: TMC Large – capacity range 700–1,800m³/h – available with TMC Smart Air® frequency control.



TELENOR SATELLITE SERVICES AS
 Snarøyveien 30 • NO-1331 Fornebu, Norway
 Tel: +47 67 89 00 00 • Fax: +47 67 89 40 41
 E-mail: customer.care@telenor.com
 Website: www.telenor.com/satellite

Telenor Satellite Services is one of the leading providers of communications solutions via satellite for users on land, at sea and in flight. A full range of satellite voice and data services is provided through four business units (Channel Sales, Corporate Networks, Sealink, and Taide Network) and two wholly-owned subsidiaries (Marlink and GMPCS Personal Communications).

Solutions for Offshore & Maritime Markets

Telenor Satellite Services' solutions are ideal for a wide variety of offshore and maritime markets, including maritime transport, production, drilling, cruise and ferry, fishing, survey/subsea, seismic, and diversified activities. Low- and high-speed voice, video, data and internet satellite communications are all available. This enables maritime industries to maintain complete control of business and routine operations at sea and shoreside while enhancing the safety of mariners and improving search and rescue capabilities on the open seas. Communications services are available through more than 400 service providers and retail organizations with over 400 points of presence populating local buying markets all over the world. Global coverage ensures seamless communications around the globe.

Telenor Satellite Services offers global on-demand and leased low- and high-speed voice and data communications services via the Inmarsat network, as well as lightweight, handheld and fixed mount Iridium phones and devices.

Sealink

The Sealink system offers one of the industry's most advanced shipboard satellite communications solutions available today, complete with the highest reliability for maritime Very Small Aperture Terminal (VSAT) communications. Offering maritime broadband communications at speeds of up to 2 megabits per second, the Sealink service enables efficient and cost-effective "at sea" communications for ship and offshore operations including internet access, video conferencing, e-mails, faxes and telephone calling. Today, more than 300 vessels all over the world are using Sealink services. More information is available at www.sealink.net.



Marlink

Marlink is a wholly-owned subsidiary and a global leader in satellite communications providing maritime and land-based customers with a variety of services. Marlink offers high-quality solutions for optimal, fast, efficient and reliable satellite communications globally including satellite airtime, software, equipment, traffic accounting and Point of Service Activation (PSA) services. Marlink has offices worldwide, including Athens, Brussels, Dubai, Hamburg, Houston, London, Oslo, Rockville, Singapore and Tokyo. More information is available at www.marlink.com.

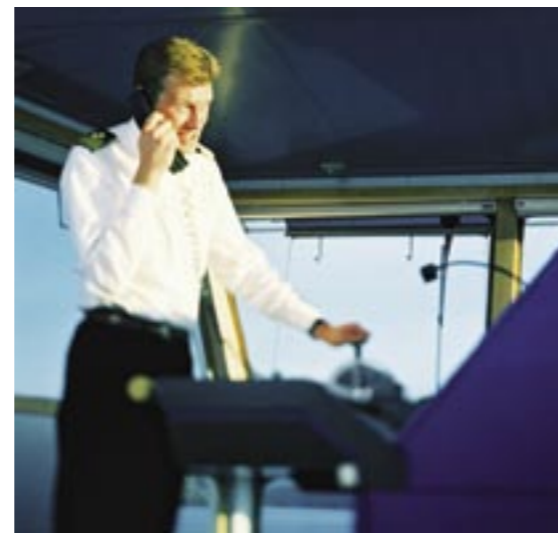

TRANBERG AS
 PO Box 8033 • NO-4068 Stavanger, Norway
 Tel: +47 51 57 89 00 • Fax: +47 51 57 89 50
 E-mail: info@tranberg.com
 Website: www.tranberg.com

Tranberg AS was founded in 1901 and has manufactured electric appliances for open deck installation since the early 1920s. The company's first cast brass navigation lantern was introduced in 1921.

All Components

The company produces:

- Navigation and signal lights
- Navigation light controller
- Floodlights
- Searchlights
- Decklights
- Helideck lights and windsock
- Junction boxes
- Cable glands
- De-icing

Tranberg appliances primarily utilize brass, aluminium and stainless steel. Products in 316 stainless steel are playing an increasingly important role in offshore and marine installations. All products are made to withstand adverse weather at sea, and signal lights, junction boxes and cable glands are available in explosion-proof models for installation in hazardous areas.

Compliance & Quality

Tranberg navigation lights comply with all relevant SOLAS and IEC requirements. The company's quality assurance system is certified by Det Norske Veritas in accordance with NS-EN ISO 9001.

Export Markets

Tranberg exports its products around the globe and has representatives worldwide.

Complete Control

Navigation and signal lights can be controlled from a panel. Tranberg control panels feature rugged solid-state components and simplified operation, ensuring reliable lamp operation.

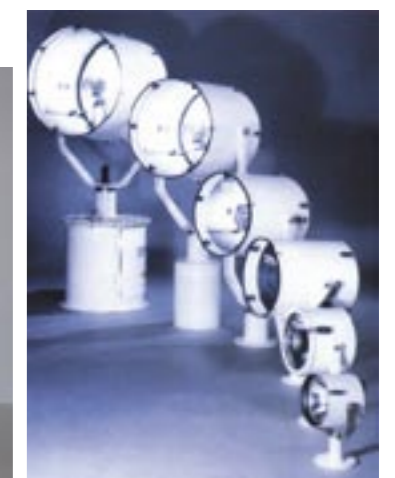



SCHAT HARDING

UMOE SCHAT-HARDING AS
 NO-5470 Rosendal, Norway
 Tel: +47 53 48 36 00 • Fax: +47 53 48 36 01
 E-mail: sales@schat-harding.com
 Website: www.schat-harding.com

The Umoe Schat-Harding Group is the global market leader in marine life-saving systems. All of its products are integrated into a total safety solution for the cruise, shipping and offshore markets. Schat-Harding's products and services are developed in close cooperation with customers and maritime authorities. The company's integrated systems are safe and streamlined to save both space and weight. The products are optimized to provide cost-effective performance for the lifetime of the vessel. All deliveries are supported by a worldwide service team.

Product Range

Schat-Harding offers a wide range of LSA (Life-Saving Appliance) products for the cruise, shipping and offshore industries. The product range, which is all integrated into one safety system from a single-source supplier, includes:

- Lifeboats
- Cruise tenders
- Free-fall systems
- Rescue boats
- Davits and winches

New Safety Regulations for Ship Owners

MSC.1/ Circ.1206 was introduced by IMO to prevent accidents with LSA systems. New amendments to SOLAS Chapter III have been adopted in MSC.78 for training, servicing and the maintenance of LSAs. All major inspections, servicing and repairs should be conducted by the representative of the OEM (Original Equipment Manufacturer) or a person appropriately trained and certified by the OEM. Hence, compulsory annual and five-year inspections, servicing and testing will require personnel who are trained and authorized by the OEM.

SHIELD – Total Safety Programme

The Schat-Harding Total Safety Programme included within the fleet service agreement is Schat-Harding's newest contribution to improving safety at sea. The Total Safety Programme will ensure that vital safety equipment is always ready to respond to any emergency. The Total Safety Programme is designed to provide a number of benefits for customers. These include:

- Prevention of accidents with LSA equipment
- Quality service of Umoe Schat-Harding brands
- Securing and extending the lifetime of LSA products
- Access to Schat-Harding's SHIELD database

- Enhancing budgeting of future maintenance costs
- Implementation of MSC.1/ Circ.1206 in a cost-effective way

Worldwide Service Network

Located strategically around the world, Schat-Harding's service stations and service partners ensure that it can offer owners of its products the servicing facilities that are necessary to satisfy the requirements of MSC.1/Circ.1206.

With in-house service stations in Norway, the UK, Germany, the Netherlands, Spain, the US, Canada, Singapore and China, in addition to service partners worldwide, Schat-Harding has the industry's largest global presence.



VESTDAVIT AS
 C. Sundtsgt. 37 • NO-5004 Bergen, Norway
 Tel: +47 55 54 92 00 • Fax: +47 55 54 92 01
 E-mail: sales@vestdavit.no • Website: www.vestdavit.no

Vestdavit AS has designed and built davits for the seismic industry, the navy and the offshore industry for more than 25 years and has been in the forefront in the development of safer and better equipment. Vestdavit offers a full range of davits for nearly every purpose and is a market leader in advanced, tailor-made boat handling systems.

Compact Construction – Simple Operations

Vestdavit's hydraulically operated davits are compact and exceptionally simple to operate. The davits have been proven effective in launching and lifting lifeboats and man-overboard boats, even in the most adverse weather conditions. All of Vestdavit's equipment is CE certified by the Marine Equipment Directive. Vestdavit is NS-ES ISO 9001:2000-certified and Achilles qualified.

Tailored Designs

Vestdavit's davits are designed to meet the specific requirements of each vessel. Ultra-compact designs are available with winch, power pack and all components integrated into the davits. Also, with the new telescopic design, boats can be placed in space-efficient recesses in the ship hull with easy-to-handle systems for deployment and recovery.

Shock Absorbers & Tension Systems

The Vestdavit dynamic shock absorber system prevents sudden stops and uncontrolled movements, promoting safety and minimizing maintenance. Davits may also be fitted with the Vestdavit tension

system, which eases the retrieval of lifeboats and man-overboard boats. These systems ensure the safe handling of boats and crew.

Davits Suited for All Ships

Vestdavit's davits are suited for use on all types of ships, offshore rigs and production platforms. Models are tailored to meet the specific needs of:

- Navies/coast guards/customs authorities
- Offshore standby and supply vessels
- Rigs and offshore platforms
- Seismic vessels
- Fishing vessels
- Merchant marine vessels
- Passenger and cruise vessels
- Ro-ro and other ferries

A-Frame Davits

The PL-type davit is a single point A-frame davit for FRC and MOB boats. It is compact and light. For further weight reduction, it can also be produced in aluminium. Lifting capacity is from 1 to 10 tonnes.

Telescopic Davits

Vestdavit's patented telescopic davit is specifically tailored to handle work boats. Due to its patented telescopic arm, it is extremely compact and space-efficient. Single arm applications can lift up to 15 tonnes. A dual-arm design is also available.

Work Boat Davits

The HN-type davit is a two-point davit for lifeboats, cruise tenders and large high-speed daughter crafts. All of the equipment is integrated on the davit structure, including the hydraulic winch and electro-hydraulic power unit. It has a flexible hook distance, independent self-tension system and dual winch system with automatic self-levelling. Lifting capacity is from 5 to 36 tonnes.

Export Markets

Vestdavit is represented by agents in the United States, the United Kingdom, the Netherlands, Germany, Spain, Greece, Singapore, Australia and New Zealand.

For contact details, please visit www.vestdavit.no





JETPAK

JETPAK NORGE AS
 Oslo Lufthavn, Gardermoen • PO Box 203
 NO-2061 Gardermoen, Norway
 Tel: +47 64 81 83 08 • Fax: +47 64 81 64 85
 E-mail: kundeservice@jetpak.no
 Website: www.jetpak.no

Jetpak offers door-to-door services for transport needs on a local scale and between the Nordic countries. Jetpak's services cover everything from spontaneous needs for rapid road or air transports to tailor-made distribution and logistics solutions. With branch offices in all the Nordic countries and 140 Nordic service centres, the company offers the best conceivable infrastructure. Its 700 courier vehicles ensure a superior local presence, while more than 2,600 flight departures every day enable Jetpak to offer the highest possible frequency and best coverage in the marketplace.

Local Deliveries

Jetpak offers a number of different alternatives for pick-up and delivery of consignments; delivery is also possible through regular, scheduled routes, making it possible to plan deliveries at specific times, day after day.

The company offers a variety of supplementary services, available at all stations:

- Storage
- Shelving and picking
- Return carriage
- Punctuality service
- Installation and functional testing

Air Shipment Services

Jetpak has offices at 140 airports throughout the Nordic region. An online tracking service allows customers to follow delivery progress.

Jetpak has developed a range of optional services including:

- Free proactive delivery-monitoring service via e-mail and SMS
- Insurance
- VIP consignments

Logistics

For shipment of systematic package flows (express consignments) with Jetpak on a daily basis, Jetpak has developed simple, streamlined logistics. JetLogistik is a tailor-made logistics tool constructed to accommodate the customer's needs down to the smallest detail. JetLogistik guarantees that consignments will always be delivered on schedule and that the customer can keep them under full control

at all times. The JetLogistik tool also enables a linking of a company's ordering system to Jetpak's, so consignments can be booked in real time directly on the screen.



PAN NORDIC LOGISTICS
 Ringager 4B • DK-2605 Brøndby, Denmark
 Tel: +45 70 28 60 00 • Fax: +45 70 28 60 01
 E-mail: import@pannordic.com
 Website: www.pannordic.com

PNL is the Nordic region's leading logistics company in the parcel market. Owned by the Danish and Norwegian postal companies, PNL offers unique solutions to businesses with transport requirements for parcels and pallets to, from and within the Nordic region.

Logistics in the Nordic Region

As companies are internationalized, the ability of logistics suppliers to handle international flows becomes increasingly important. PNL's base is in the Nordic region, but thanks to a comprehensive network and international partnerships, the company reaches businesses and individuals in 190 countries throughout the world. The company cooperates closely with postal companies in Estonia, Finland, the Faeroe Islands, Greenland, Iceland, Poland and Sweden. PNL was established in 1997 and currently has 160 employees in Denmark, Finland, Norway and Sweden, where the head office is located. During 2005, turnover exceeded SEK 1.1 billion.



CarryOn from Europe

PNL's solutions are called CarryOn and are characterized by huge flexibility. By always starting with customers' needs and using these to create physical and electronic products and services, PNL does not just deliver shipments, but also security and additional value. The solutions are easy to use, reliable and cost efficient, with tracking to 55 countries. For companies that import shipments from Europe to the Nordic countries, PNL offers specialized logistics import solutions.



PNL's import operations have increased since its establishment in 2002. Sales have increased four-fold and several international companies have been added to the list of customers. In that many international companies have their central warehouses in Germany, Belgium and the Netherlands, the need for logistics solutions from Europe to the Nordic region has increased. At present, a number of PNL's linehaul vehicles depart daily from various parts of Europe to the Nordic countries.

PNL is currently working to strengthen and develop its position in relation to its European import customers. Consequently, an office was opened in Venlo in the Netherlands in 2005.

For more information, please visit PNL's website (pannordic.com) or send an e-mail to import@pannordic.com.





Pareto Securities

PARETO SECURITIES ASA
 Dronning Mauds Gate 3 • PO Box 1411 Vika
 NO-0115 Oslo, Norway
 Tel: +47 22 87 87 00 • Fax: + 47 22 87 87 10
 E-mail: info@pareto.no • Website: www.pareto.no

Pareto is a leading and independent financial services company in the Norwegian capital market, focused on oil, energy, oil services and transportation. Pareto continues its development as a focused and profitable company with considerable top-line growth and increased profitability.

Services

Pareto's services include:

- Equity and debt financing and brokerage

- M&A, corporate finance
- Shipping/offshore asset trading and chartering
- Oil license trading

International Placing Power

The combination of local presence and international investor contacts forms the basis for Pareto Securities' placement power in the stock and bond market. The company's international clients account for more than 50 percent of its revenue. This enables the company to complete many large and complex projects.

The company's financial advisory services are anchored in industrial knowledge and proximity to investors. As an independent financial adviser Pareto offers a complete range of financial services, ranging from stock and bond offerings, stock exchange

listings and placings, to mergers/demergers and acquisitions/sales of businesses or companies.

Research is the Engine

Pareto is a research-driven company, with more than seventy energy and transportation stocks covered. The number is expanding, with new IPO candidates and selected international peer group coverage.

Pareto rates highly in the areas of:

- Company knowledge
- Industrial knowledge
- Knowledge of the Norwegian capital markets
- Case analysis

- Business ideas
- Placing power
- Order execution
- Back office quality

Executive research products include:

- *Shipping Weekly*
- *Rig Weekly*
- *Supply & Subsea Weekly*
- *E&P Weekly*

Pareto is also a major and independent player in the Norwegian bond market. This involvement enables the company to offer its corporate clients debt financing. It also offers Norwegian and international investors investment opportunities in fixed income securities.



Eitzen chemical carrier.



WIKBORG REIN

WIKBORG REIN
 Kronprinsesse Märthas pl. 1
 PO Box 1513 Vika • NO-0117 Oslo, Norway
 Tel: +47 22 82 75 00 • Fax: +47 22 82 75 01/02
 E-mail: oslo@wr.no • Website: www.wr.no

Wikborg Rein is one of Norway's leading law firms, with more than 150 lawyers in Oslo, Bergen, London, Singapore, Kobe, and Shanghai. The firm's long-standing presence overseas provides extensive international experience and expertise. A thorough understanding of the client's business, combined with the highest professional standards, ensures that each client receives the best possible legal assistance.

Wikborg Rein's Shipping Offshore group is Norway's leading maritime practice in one of the country's largest law firms. With offices in Norway's major commercial centres, Oslo and Bergen, and offices overseas in London, Kobe, Shanghai and Singapore, Wikborg Rein has a strong international profile. The firm serves clients across the full range of shipping, transport, and offshore activities, including marine insurers, shipowners, various offshore companies, offshore/shipyards and equipment providers, shipbrokers and agents, and shipping banks, as well as companies related to freight forwarding and land transportation.

Assistance

Wikborg Rein's assistance includes:

- Registration of ships, choice of flag and registration
- Control and classification of ships
- Building and repair contracts for ships and rigs
- Conversion and modification contract for ships, rigs and FPSOs
- Sale and purchase of ships
- Ships finance, lien and mortgage
- Organization and management of ship owners (corporate law, tax etc.)

- Casualty work, including owner's liability, limitation of liability, liability for oil spill and collisions, maritime inquiry and other public law issues
- The law of chartering, including bills of lading and charter parties for ships, rigs and FPSOs
- Cargo claims
- Crew matters
- Competition law issues related to shipping
- Arrest, salvage and general average
- Maritime insurance, including Hull & Machinery and P&I claims and interpretation of club rules
- Freight forwarding and land transportation

Company Addresses

Bergen:

PO Box 1233 Sentrum
 NO-5811 Bergen, Norway
 Tel: +47 55 21 52 00
 Fax: +47 55 21 52 01
 E-mail: bergen@wr.no

London:

One Knightrider Court
 EC4V 5JP London
 England

Tel: +44 20 7236 4598
 Fax: +44 20 7236 4599
 E-mail: london@wr.no

Singapore:

16 Stanley Street
 Singapore 068735
 Tel: +65 6438 4498
 Fax: +65 6438 4496
 E-mail: singapore@wr.no

Kobe:

Sannomiya Kokusai Bldg. 5F
 1-30, Hamabe-dori 2-chome
 Chuo-ku
 Kobe 651-0083
 Japan
 Tel: +81 78 272 1777
 Fax: +81 78 272 1788
 E-mail: kobe@wr.no

Shanghai:

12 Zhong Shan Road E.1
 20002 Shanghai
 China
 Tel: +86 21 6339 0101
 Fax: +86 21 6339 0606
 E-mail: shanghai@wr.no

afghanistan

Kabul – Embassy
Tel: +870 762 596 925
Fax satellite: +870 6000 61156
E-mail: emb.kabul@mfa.no

albania

Tirana – Embassy
Pr "Dëshmorët e 4 shkurtit", nr 5, Tirana
Tel: +355 4 256929, +355 4 221666, Fax: +355 4 221507
E-mail: emb.tirana@mfa.no

angola

Luanda – Embassy
Rua de Benguela 17, Bairro Patrice Lumumba, Luanda
Tel: +224 222 447522/222 447922/ 222 449396
Fax: +244 222 446248
Tel. satellite: 871 761 964840, Fax satellite: 871 682 421256
E-mail: emb.luanda@mfa.no

argentina

Buenos Aires – Embassy
Esmeralda 909, 3B, 1007 Buenos Aires
Tel: +54 11 4312 2204, Fax: +54 11 4315 2831
E-mail: emb.buenosaires@mfa.no

azerbaijan

Baku – Embassy
6-10 Vagif Mustafa-zade kucesi, 370004 Baku
Tel: +994 12 4974325 / 4974326 / 4974327, Fax: +994 12 4973798
E-mail: emb.baku@mfa.no

austria

Vienna – Embassy
Reisner Str. 55, A-1030 Vienna
Tel: +43 1 715 6692, Fax: +43 1 712 6552
E-mail: emb.vienna@mfa.no

australia

Canberra – Embassy
17 Hunter Street; Yarralumla, Canberra ACT 2600
Tel: +61 2 6273 3444, Fax: +61 2 6273 3669
E-mail: emb.canberra@mfa.no

bangladesh

Dhaka – Embassy
Road 111, House 9, Gulshan, Dhaka 1212
Tel: +880 2 881 6276, Fax: +880 2 882 3661
E-mail: emb.dhaka@mfa.no

belgium

Brussels – Embassy
Rue Archimede 17, B-1000 Brussels
Tel: +32 2 646 0780, Fax: +32 2 646 2882
E-mail: emb.brussels@mfa.no

bosnia-hercegovina

Sarajevo – Embassy
Ferhadija 20; 2nd floor, 71000 Sarajevo
Tel: +387 33 254 000, Fax: +387 33 666505
E-mail: emb.sarajevo@mfa.no

brazil

Brasilia – Embassy
SES 807 Avenida das Nações; Lote 28, CEP 70, BR-418-900 Brasilia - DF
Tel: +55 61 3443 8722, +55 61 3443 8720, Fax: +55 61 3443 2942
E-mail: emb.brasilia@mfa.no

Rio de Janeiro – Consulate General

Praia do Flamengo, 344/9, BR-22210-030 Rio de Janeiro
Tel: +55 21 2553 5505, Fax: +55 21 2553 1925
E-mail: cons.gen.riodejaneiro@mfa.no

Rio de Janeiro – Innovation Norway

Rua Lauro Muller, 116-Suite 2206
Torre do Rio Sul/Botafogo-RJ
BR-22290-160
Tel: +55 21 2541 7732
Fax: +55 21 2275 0161
E-mail: riodejaneiro@invanor.no
Website: www.invanor.no/brazil

bulgaria

Sofia – Embassy
54 B, Dondukov Blvd., Sofia 1000
Tel: +359 2 92 11 95, Fax: +359 2 981 90 10
E-mail: emb.sofia@mfa.no

canada

Ottawa – Embassy
Royal Bank Centre; Suite 532; 90 Sparks Street, Ottawa, Ont. K1P 5B4
Tel: +1 613 238 6571, Fax: +1 613 238 2765
E-mail: emb.ottawa@mfa.no

Toronto – Innovation Norway

2 Bloor Street West Suite 504
Toronto
Ontario M4W 3E2
Tel: +1 416 920 0434
Fax: +1 416 920 5982
E-mail: toronto@invanor.no
Website: www.invanor.no/toronto

chile

Santiago de Chile – Embassy
San Sebastián 2639; Of. 509, Las Condes, Santiago
Tel: +56 2 234 2888 / 89, Fax: +56 2 234 2201
E-mail: emb.santiago@mfa.no

china

Beijing – Embassy
1, Dong Yi Jie; San Li Tun, CN-Beijing 100600
Tel: +86 10 6532 2261 / 1329 / 4176, Fax: +86 10 6532 2392
E-mail: emb.beijing@mfa.no

Shanghai – Consulate General

12 Zhongshan Dong Yi Road, CN-Shanghai 200002
Tel: +86 21 6323 9988, Fax: +86 21 6323 3938
E-mail: cons.gen.shanghai@mfa.no

colombia

Bogota – Embassy
Edificio Fuducafe, Piso 8 #801, Carrera 9 no 73-44, Bogota
Tel: +57 1 317 7851-54, Fax: +57 1 317 7858
E-mail: emb.bogota@mfa.no

croatia

Zagreb – Embassy
Petrijska 9, HR-10 000 Zagreb
Tel: +385 1 492 2831, Fax: +385 1 492 2832
E-mail: emb.zagreb@mfa.no

cuba

Havana – Embassy
Calle 30 #315, betw. 3rd and 5th Avenue, Miramar, Playa. La Habana
Tel: +53 7 204 0696 / +53 7 204 4411, Fax: +53 7 204 0699
Tel satellite: +47 22 24 03 10, Fax satellite: +874 600059661
E-mail: emb.havana@mfa.no

czech republic

Prague – Embassy
Hellichova 1, CZ-11800 Prague 1 Malá Strana
Tel: +420 2 57323737, 57321768/69, Fax: +420 2 57326827
E-mail: emb.prague@mfa.no

Prague – Innovation Norway

Royal Norwegian Embassy
Commercial Section
Na Příkopě 21
PO Box 102
CZ-11001 Prague 1
Tel: +4202 2481 0923
Fax: +4202 2481 0002
E-mail: prague@invanor.no
Website: www.invanor.no/prague

denmark

Copenhagen – Embassy
Amaliegade 39, 1256 Copenhagen K
Tel: +45 33 140124, Fax: +45 33 140624
E-mail: emb.copenhagen@mfa.no

Copenhagen – Innovation Norway

Amaliegade 39, 1256 Copenhagen K
Tel: +45 33 140124, Fax: +45 33 140824
E-mail: copenhagen.trade@invanor.no
copenhagen.travel@invanor.no

egypt

Cairo – Embassy
8, El Gezrah Street; Zamalek, ET-Cairo
Tel: +20 2 735 3340, Fax: +20 2 737 0709
E-mail: emb.cairo@mfa.no

eritrea

Asmara – Embassy
Street 173-1 # 11,
PO Box 5801, Asmara
Tel: +291 1 12 21 38/12 21 48, Fax: +291 1 12 21 80
E-mail: emb.asmara@mfa.no

estonia

Tallinn – Embassy
Harju 6, EE-15054 Tallinn
Tel: +372 62 71000, Fax: +372 62 71001
E-mail: emb.tallinn@mfa.no

Tallinn – Innovation Norway

c/o Royal Norwegian Embassy
Harju Str. 6
EE-15054 Tallinn
Tel: +372 6313 466
Fax: +372 6313 468
E-mail: tallinn@invanor.no

ethiopia

Addis Abeba – Embassy
Buna Road, Mekanissa, Addis Abeba
Tel: +251 137 107 99, Fax: +251 1 711255
E-mail: emb.addisabeba@mfa.no

finland

Helsinki – Embassy
Rehbindervägen 17, FIN-00150 Helsinki
Tel: +358 9 686 0180, Fax: +358 9 657 807
E-mail: emb.helsinki@invanor.no

Helsinki – Innovation Norway

Eriksgratan 2
FIN-00100 Helsinki
Tel: +358 9 612 9690
Fax: +358 964 0053
E-mail: helsinki@invanor.no

france

Paris – Embassy
28, Rue Bayard, F-75008 Paris
Tel: +33 1 5367 0400, Fax: +33 1 5367 0440
E-mail: emb.paris@mfa.no

germany

Berlin – Embassy
Rauchstr. 1, D-10787 Berlin
Tel: +49 30 505050, Fax: +49 30 505055
E-mail: emb.berlin@mfa.no

Düsseldorf – Innovation Norway

c/o Königlich Norwegisches Generalkonsulat
Handels- und Technologieabteilung
Benningsenplatz 1
D-40474 Düsseldorf
Tel: +49 21 14 58 90
Fax: +49 21 14 58 91 10
E-mail: dusseldorf@invanor.no
Website: www.invanor.no/dusseldorf

Hamburg – Innovation Norway (Tourism)

Neuer Wall 41
DE-20354 Hamburg
Postfach 11 3317
DE-20433 Hamburg
Tel: +49 40 22 94 15 0
Fax: +49 40 22 94 15 88
E-mail: hamburg@invanor.no
Website: www.invanor.no/dusseldorf

greece

Athens – Embassy
23, Vas Sofias avenue, GR-106 74 Athens
Tel: +30 210 7246173, Fax: +30 210 7244989,
E-mail: emb.athens@mfa.no

guatemala

Guatemala – Embassy
14 Calle 3-51, Zona 10, Edificio Murano Center, Nivel 15, Ca-Guatemala 01010
Tel: +502 2366 5908, Fax: +502 2366 5928
E-mail: emb.guatemala@mfa.no

hungary

Budapest – Embassy
Ostrom u. 13, H-1015, Budapest
Tel: +36 1 212 9400 / 04 / 05, Fax: +36 1 212 9410
E-mail: emb.budapest@mfa.no

iceland

Reykjavik – Embassy
Fjölugt. 17, IS-101 Reykjavik
Tel: +354 520 0700, Fax: +354 552 9553
E-mail: emb.reykjavik@mfa.no

india

New Delhi – Embassy
50 C Shantipath; Chanakyapuri, IND-110 021 New Delhi
Tel: +91 11 51 77 92 00, Fax: +91 11 51 68 01 45
E-mail: emb.newdelhi@mfa.no

indonesia

Jakarta – Embassy
Menara Rajawali Building, 25th floor, Jl Mega Kuningan Lot no 5.1,
Kawasan Mega Kuningan, Jakarta 12950
Tel: +62 21 576 1523, Fax: +62 21 576 1537
E-mail: emb.jakarta@mfa.no

iran

Teheran – Embassy
No 201 Dr. Lavasani St. (Ex-Farmanieh), Corner of Sonbol, Teheran
Tel: +98 21 2229 1333, Fax: +98 21 2229 2776
E-mail: emb.tehran@mfa.no

ireland

Dublin – Embassy
34 Molesworth Street, IRL-Dublin 2
Tel: +353 1 662 1800, Fax: +353 1 662 1890
E-mail: emb.dublin@mfa.no

israel

Tel Aviv – Embassy
40 Einstein Street, Canon Ramat Aviv, 13. Etl., 69101 Tel Aviv
Tel: +972 3 744 1490, Fax: +972 3 744 1498
E-mail: emb.telaviv@mfa.no

italy

Rome – Embassy
Via delle Terme Deciane 7, I-00 153 Rome
Tel: +39 06 571 7031, Fax: +39 06 571 70326
E-mail: emb.rome@mfa.no

Milan – Innovation Norway

Reale Ambasciata di Norvegia
Ufficio Commerciale e del Turismo
Via G. Puccini, 5
I-20121 Milan
Tel: +39 02 854 514 11
Fax: +39 02 854 514 30
E-mail: milan@invanor.no
Website: www.invanor.no/milan

ivory coast

Abidjan – Embassy
Immeuble N Zarama, Boulevard Lagunaire, 5th floor, Abidjan
Tel: +225 20 222534 / 212166, Fax: +225 20 219 199
E-mail: emb.abidjan@mfa.no

japan

Tokyo – Embassy
Minami Azabu 5-12-2; Minato-Ku, J-Tokyo 106-0047
Tel: +81 3 3440 2611, Fax: +81 3 3440 2620
E-mail: emb.tokyo@mfa.no

jordan

Amman – Embassy
25 Damascus Street, Abdoun, Amman
Tel: +962 6 593 1646-48, Fax: +962 6 593 1650
E-mail: emb.amman@mfa.no

kenya

Nairobi – Embassy
Lion Place, Waiyaki Way, Nairobi
Tel: +254 20 4451510/1/2/3/4/5/6, Fax: +254 20 4451517
E-mail: emb.nairobi@mfa.no

latvia

Riga – Embassy
14 Zirgu iela, LV-1050 Riga
Tel: +371 7814100, Fax: +371 7814108
E-mail: emb.riga@mfa.no

Riga – Innovation Norway

Vainu Street 1, 3rd floor
LV-1050 Riga
Tel: +371 722 42 33
Fax: +371 722 40 54
E-mail: riga@invanor.no

lebanon

Beirut – Embassy
Bliss Street, Dimashki Bldg, Beirut
Tel: +961 1 365 704 / +961 1 372 977/+961 1 372 978
Fax: +961 1 372 979
E-mail: noremble@cyberia.net.lb

lithuania

Vilnius – Embassy
Mesiniu g. 5/2, 01015 Vilnius
Tel: +370 5 2610000, Fax: +370 5 2610100
E-mail: emb.vilnius@mfa.no

Vilnius – Innovation Norway

Innovation Norway
Royal Norwegian Embassy Commercial Section
PO Box 564
01014 Vilnius - 1
Tel: +370 5 2624020 / +370 5 212 2746
Fax: +370 5 212 3186
E-mail: vilnius@invanor.no

norway abroad

macedonia

Skopje – Embassy

Palata Uhija, Teodosie Gologanov 59-2A, 91000 Skopje
Tel: +389 2 3129 165, Fax: +389 2 3111 038
E-mail: emb.off.skopje@mfa.no

madagascar

Antananarivo – Embassy

Explorer Business Park, bâtiment D2, Ankorandrano, 101 Antananarivo
Tel: +261 20 22 305 07, Fax: +261 20 22 377 99
E-mail: emb.antanarivo@mfa.no

malawi

Lilongwe – Embassy

Arwa House, City Centre, P/Bag B 323, Lilongwe 3
Tel: +265 1 774211 / 771212, Fax: +265 1 772845
E-mail: emb.lilongwe@mfa.no

malaysia

Kuala Lumpur – Embassy

Suite CD, 53rd floor Empire Tower, Jalan Tun Razak, 50400 Kuala Lumpur
Tel: +60 3 2175 0300, Fax: +60 3 2175 0308
E-mail: emb.kualalumpur@mfa.no

mexico

Mexico D.F. – Embassy

Avenida Virreyes 1460; Col Lomas Virreyes, 11000 Mexico D.F.
Tel: +52 55 5540220-21, Fax: +52 55 52023019
E-mail: emb.mexico@mfa.no

morocco

Rabat – Embassy

9, rue de Khenifra, Rabat
Tel: +212 3 7764084-6, Fax: +212 3 7764088
E-mail: emb.rabat@mfa.no

mozambique

Maputo – Embassy

Ave. Julius Nyerere 1162, Maputo
Tel: +258 21 480 100/+ 258 21 485 072 to 75
Fax: +258 21 480 107/+ 258 21 485 076
E-mail: emb.maputo@mfa.no

nepal

Katmandu – Embassy

Surya Court, Pulchowk, Lalitpur
Tel: +977 1 5545307-8, Fax: +977 1 5545226
E-mail: emb.katmandu@mfa.no

the netherlands

The Hague – Embassy

Lange Vijverberg 11, NL-2513 AC The Hague
Tel: +31 70 311 7611, Fax: +31 70 365 9630
E-mail: emb.hague@mfa.no

Rotterdam – Royal Norwegian Consulate General (Honorary)

's-Landswerf 20-21, 3063 GA Rotterdam
Tel: +31 10 414 4488, Fax: +31 10 412 6324
E-mail: norencon@xs4all.nl

nicaragua

Managua – Embassy

Plaza España, 100 mtr. al Oeste, Managua
Tel: +505 2 665197-9, Fax: +505 2 663303
E-mail: emb.managua@mfa.no

nigeria

Abuja – Embassy

Plot 1529, T.Y. Danjuma Street, Asokoro, Abuja
Tel: +234 9 3149127, Tel. satellite : +882 165 420 7489/
+882 165 420 7515, Fax: +234 9 3149309
E-mail: emb.abuja@mfa.no

pakistan

Islamabad – Embassy

H 25, Str. 19, F 6/2, Islamabad
Tel: +92 51 227 9720-23, Fax: +92 51 227 9729
E-mail: emb.islamabad@mfa.no

palestinian territory

Al Ram – Representative Office to the Palestinian authorities (West Bank/Gaza)

World Bank Building (o/o Rosary Sisters Convent), Dahiat Al-Bareed, Al Ram, West Bank
Tel: +972 2 234 5050, Fax: +972 2 234 5079
E-mail: rep.office.alaram@mfa.no

philippines

Manila – Embassy

Petron Mega Plaza Bldg., 21st floor, 358 Senator Gil Puyat Avenue, Makati City, Metro Manila
Tel: +63 2 886 3245-49, Fax: +63 2 886 3384
E-mail: emb.manila@mfa.no

poland

Warsaw – Embassy

ul. Fr. Chopina 2A, PL-00-559 Warsaw

Tel: + 48 22 696 4030, Fax: +48 22 628 0938
E-mail: emb.warsaw@mfa.no

Warsaw – Innovation Norway

c/o Royal Norwegian Embassy
Warta Tower
ul. Chmielna 85/87
PL-00-805 Warsaw
Tel: +48 22 581 0 581
Fax: +48 22 581 0 981
E-mail: warsaw@invanor.no
Website: www.invanor.no/warsaw

portugal

Lisbon – Embassy

Avenida D. Vasco da Gama 1, P-1400-127 Lisbon
Tel: +351 21 301 5344, Fax: +351 21 301 6158
E-mail: emb.lisbon@mfa.no

romania

Bucharest – Embassy

Strada Dumbrava Rosie 4; 020463 Bucharest
Tel: +40 21 210 0274 / 76 / 77, Fax: +40 21 210 0275
E-mail: emb.bucharest@mfa.no

russia

Moscow – Embassy

Ulitsa Povarskaya 7, RUS-131940 Moscow
Tel: +74 95 933 1410, Fax: +74 95 933 14 11/12
E-mail: emb.moscow@mfa.no

Murmansk – Consulate General

Ulitsa Sofii Perovskoj 5, RUS-183038 Murmansk
Tel: +7 815 2 400 600, Fax: +7 815 2 457 451/+7 815 2 456 871
E-mail: cons.gen.murmansk@mfa.no

St. Petersburg – Consulate General

Nevsky Prospekt 25, RUS-191186 St. Petersburg
Tel: +7 812 336 64 20, Fax: +7 812 336 64 21
E-mail: cons.gen.stpetersburg@mfa.no

St.Petersburg – Innovation Norway

Kaluzhskij per.3
RUS-193015 St. Petersburg
Tel: +7812 326 9037
Fax: +7812 326 9038
E-mail: st.petersburg@invanor.no

saudi arabia

Riyadh – Embassy

Diplomatic Quarter, Riyadh
Tel: +966 1 488 1904, Fax: +966 1 488 0854
E-mail: emb.riyadh@mfa.no

serbia and montenegro

Beograd – Embassy

Uzicka 43, YU-11040 Beograd
Tel: +381 11 367 0404-05, Fax: +381 11 369 0158
E-mail: emb.belgrade@mfa.no

singapore

Singapore – Embassy

16 Raffles Quay; No 44-01 Hong Leong Bldg., Singapore 048581
Tel: +65 6220 7122, Fax: +65 6220 2191
E-mail: emb.singapore@mfa.no

slovakia

Bratislava – Embassy

Palisády 29, 811 06 Bratislava
Tel: +421 2 59 10 01 00, Fax: +421 2 59 10 01 15
E-mail: emb.bratislava@mfa.no

slovenia

Ljubljana – Embassy

Adjovscina 4/8, 1000 Ljubljana
Tel: +386 1 300 2140, Fax: +386 1 300 2150
E-mail: emb.ljubljana@mfa.no

south africa

Johannesburg – Innovation Norway

14th Floor, Sandton City Office Tower
PO Box 785436
Sandton 2146
Tel: +2711784 8150
Fax: +2711784 8153
E-mail: johannesburg@invanor.no

Pretoria – Embassy

1 Parioli Building A2, 1166 Park Street, Hatfield 0083
Tel: +27 12 342 6100, Fax: +27 12 342 6099
E-mail: emb.pretoria@mfa.no

south korea

Seoul – Embassy

258-8 Itaewon-Dong, Yongsan-Ku, Seoul 140-200
Tel: + 82 2 795 6850, Fax: +82 2 798 6072

E-mail: emb.seoul@mfa.no

spain

Madrid – Embassy

Edificio "La Piramide", Paseo de la Castellana 31, 9 piso, 28046 Madrid
Tel: +34 91 310 3116, Fax: +34 91 310 4326/319 0969
E-mail: emb.madrid@mfa.no

sri lanka

Colombo – Embassy

34 Ward Place, Colombo 7
Tel: +94 11 2469 611-12, 2469 609, Fax: +94 11 2695 009
E-mail: emb.colombo@mfa.no

sudan

Khartoum – Embassy

House no. 63, Street 49, Khartoum II
Tel: +249 183 578336, 578343, 578345, 576788,
Fax: +249 183 577180
E-mail: emb.khartoum@mfa.no

sweden

Stockholm – Embassy

Skarpögatan 4, S-115 27 Stockholm
Tel: +46 8 665 6340, Fax: +46 8 782 9899
E-mail: emb.stockholm@mfa.no

Stockholm – Innovation Norway

Adolf Fredriks Kyrkogata 13
SE-103 67 Stockholm
Tel: +46 8 791 83 00
Fax: +46 8 24 98 00
E-mail: stockholm@invanor.no

switzerland

Bern – Embassy

Bubenberglplatz 10, CH-3011 Bern
Tel: +41 31 310 5555, Fax: +41 31 310 5550
E-mail: emb.bern@mfa.no

syria

Damascus – Embassy

Shaheen Bldg., 1st floor, Ahmad Shawki Street, Jahez Garden, Malki, Damascus
Tel: +963 11 611 5053 / +963 11 611 5185, Fax: +963 11 613 1159
E-mail: emb.damascus@mfa.no

tanzania

Dar es Salaam – Embassy

160; Mirambo Street, Dar es Salaam
Tel: +255 22 211 3366, Fax: +255 22 211 6564
E-mail: emb.daressalaam@mfa.no

thailand

Bangkok – Embassy

UBC II Building, 18th floor, 591 Sukhumvit Road, Soi 33, Bangkok 10110
Tel: +66 2 302 6415, Fax: +66 2 262 0218
E-mail: emb.bangkok@mfa.no

tunisia

Tunis – Embassy

Immeuble Norvège, Rue du Lac Neuchâtel, Les Berges du Lac, 1053 Tunis
Tf: +216 71 861 777, Fax: +216 71 961 080
E-mail: emb.tunis@mfa.no

turkey

Ankara – Embassy

Kirkipinar Sokak No. 16; 06540 Carikaya, Ankara
Tel: +90 312 405 8010, Fax: +90 312 443 0544
E-mail: emb.ankara@mfa.no

Istanbul – Innovation Norway

Aytar Cad., Aydin Sokak, Aydin is Merkezi
A Blok No: 2, D:7,1 Levent
TR-80620
Tel: +90 212 2844 362 / 63 / 65
Fax: +90 212 2844 364
E-mail: istanbul@invanor.no
Website: www.invanor.no/istanbul

uganda

Kampala – Embassy

8 Acacia Avenue, Kololo, Kampala
Tel: +256 41 343621, Fax: +256 41 343936
E-mail: emb.kampala@mfa.no

ukraine

Kiev – Embassy

Vul. Striletska 15, 252034 Kiev
Tel: +380 44 590 04 70, Fax: +380 44 234 0655
E-mail: emb.kiev@mfa.no

united arab emirates

Abu Dhabi – Embassy

Hamdan Street, Al Masoud Tower; 10th floor, Abu Dhabi
Tel: + 971 2 621 1221, Fax: +971 2 621 3313
E-mail: emb.abudhabi@mfa.no

united kingdom

Edinburgh – Consulate General

86 George Street, GB-Edinburgh EH2 3BU
Tel: +44 131 226 5701, Fax: +44 131 220 4976
E-mail: cons.gen.edinburgh@mfa.no

London – Embassy

25 Belgrave Square, London SW1X 8QD
Tel: +44 20 7591 5500, Fax: +44 20 7245 6993
E-mail: emb.london@mfa.no

London – Innovation Norway

Trade and Technology Office
Charles House 5 Lower Regent Street
SW1Y 4LR
Tel: +44 207 389 8800
Fax: +44 207 9730 189
E-mail: london@invanor.no
Website: www.invanor.no/london

usa

Boston – Innovation Norway

133 Federal Street, Suite 901
Boston, MA 02110
Tel: +1 617 369 7870
Mobile: +1 617 818 3900
Fax: +1 617 369 7820
E-mail: boston@invanor.no
website: www.invanor.no/usa

Houston – Consulate General

2777 Allen Parkway; Suite 1185, Houston, TX 77019-2136
Tel: +1 713 521 2900, Fax: +1 713 521 9648
E-mail: cons.gen.houston@mfa.no

Minneapolis – Consulate General

800 Foshay Tower; 821 Marquette Avenue, Minneapolis, MN 55402
Tel: +1 612 332 3338, Fax: +1 612 332 1386
E-mail: cons.gen.minneapolis@mfa.no

New York – Consulate General

825 Third Avenue; 38th floor, New York, NY 10022-7584
Tel: +1 212 421 7333, Fax: +1 212 754 0583
E-mail: cons.gen.newyork@mfa.no

New York – Innovation Norway

655 Third Avenue, Room 1810
New York, NY 10017-9111
Tel: +1 212 885 9700
Fax: +1 212 885 9710
E-mail: newyork@invanor.no
Website: www.invanor.no/usa

San Francisco – Consulate General

20 California Street; 6th floor, San Francisco, CA 94111-4803
Tel: +1 415 986 0766-8, Fax: +1 415 986 3318
E-mail: cons.gen.sanfrancisco@mfa.no

Washington DC – Embassy

2720 34th Street N.W., Washington DC 20008-2714
Tel: +1 202 333 6000, Fax: +1 202 337 0870
E-mail: emb.washington@mfa.no

venezuela

Caracas – Embassy

Centro Lido, Torre A, Piso 9, Oficina 92-A; Avenida Fransisco de Miranda, El Rosal, Caracas
Tel: +58 212 953 0671 / 0269 / 1973, Fax: + 58 212 953 6877
E-mail: emb.caracas@mfa.no

vietnam

Hanoi – Embassy

Metropole Centre; Suite 701/072, 56 Ly Thai To Street, Hanoi
Tel: +84 4 826 2111, Fax: +84 4 826 0222
E-mail: emb.hanoi@mfa.no

zambia

Lusaka – Embassy

Corner Birdage Walk / Halle Salassie Avenue, Lusaka
Tel: +260 1 252188, 252626, 252637, Fax: +260 1 253915
E-mail: emb.lusaka@mfa.no

zimbabwe

Harare – Embassy

5 Lanark Road; Belgrave, Harare
Tel: +263 4 252426, Fax: +263 4 252430
E-mail: emb.harare@mfa.no

find new business partners in norway



The Official Norwegian Trade Portal

At **www.nortrade.com** you will find up-to-date information on more than 3,400 Norwegian manufacturers and exporters within 30 different industries. There you will find a search tool which allows you to perform searches for companies, products or persons in the Norwegian Export Directory.

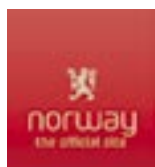

www.norway.info

“Norway – the official site” provides extensive background information on Norway, as well as news and details of Norwegian-related events abroad. The large number of articles on politics, travel, culture, business, education, research and history are presented by the Norwegian Ministry of Foreign Affairs and its partners. “Norway – the official site” has been established in 90 countries and in 18 languages.

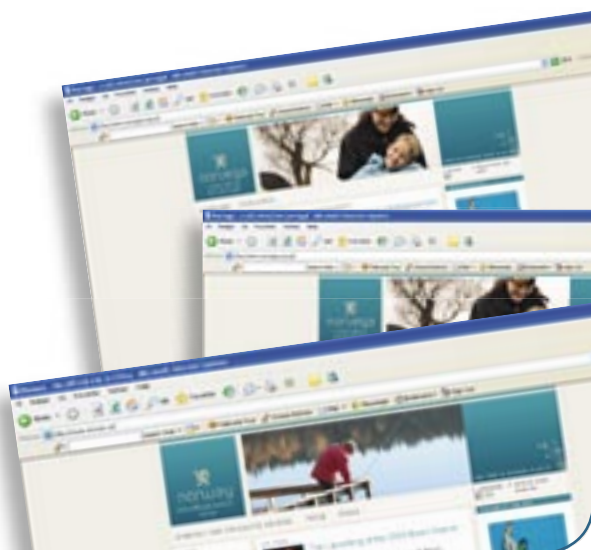

Innovation Norway promotes nationwide industrial development profitable to both the business economy and Norway's national economy, and helps realize the potential of different districts and regions by contributing to innovation, internationalization and promotion. The company has approximately 700 employees. Headquartered in Oslo, Innovation Norway has offices in over 30 countries worldwide, along with all of the counties across Norway.

English-language information about Innovation Norway is available at **www.innovationnorway.no/english**.



Produced by:



In cooperation with:

